

KIT D'APPRENTISSAGE ET DE JEUX

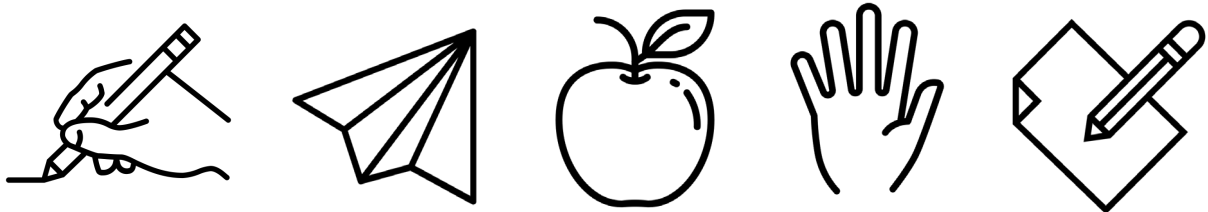

LEARN AND PLAY KIT



Tu as besoin de : / You need:

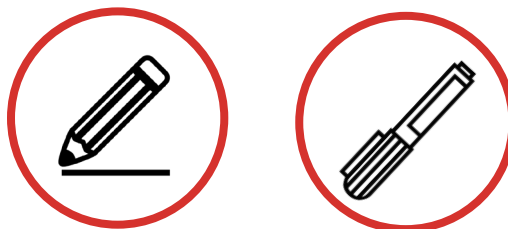

Idées pour les enfants, les jeunes et les familles
Ideas for Kids, Youth and Families

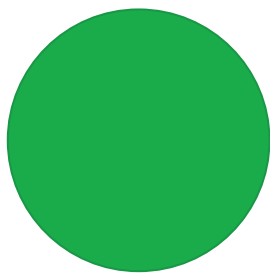

VERT / GREEN

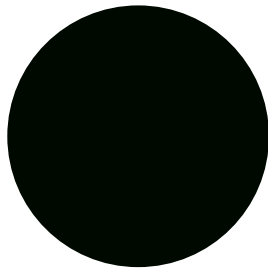

NOIR / BLACK

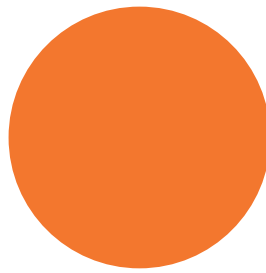

ORANGE / ORANGE

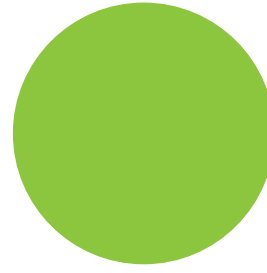

VERT CLAIR / LIGHT GREEN

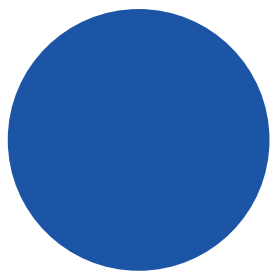

BLEU / BLUE

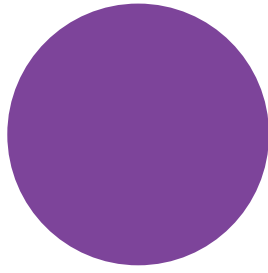

VIOLET / PURPLE

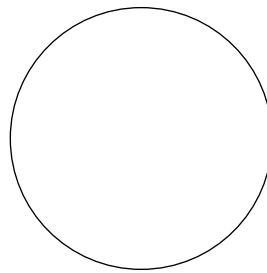

BLANC / WHITE

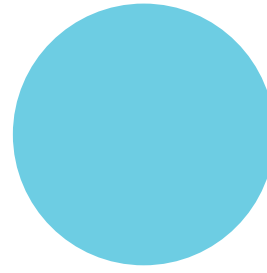

BLEU CLAIR / LIGHT BLUE

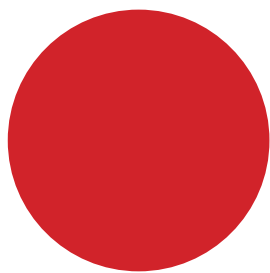

ROUGE / RED

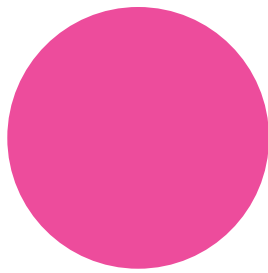

ROSE / PINK

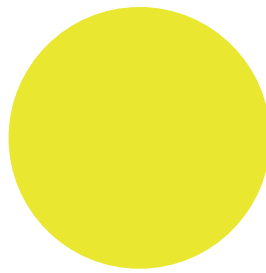

JAUNE / YELLOW

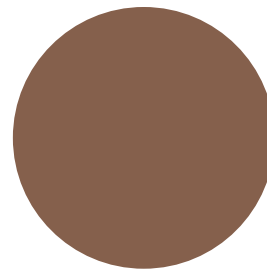

MARRON / BROWN

Combine la bonne couleur avec le bon mot. /
Combine the right color with the right word.



ROUGE / RED

ROSE / PINK

JAUNE / YELLOW

MARRON / BROWN

VERT / GREEN

NOIR / BLACK

ORANGE / ORANGE

VERT CLAIR / LIGHT GREEN

BLEU / BLUE

VIOLET / PURPLE

BLANC / WHITE

BLEU CLAIR / LIGHT BLUE

LES VÊTEMENTS / CLOTHES

Écris le bon mot sous la bonne image.

Colorie les images. / Write the right word under the right picture. Paint the pictures in colour.



Save the Children



le t-shirt

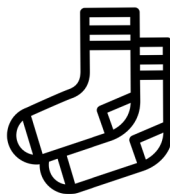
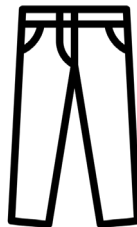
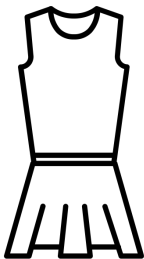
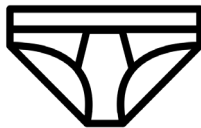
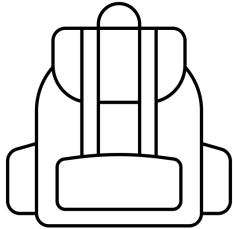
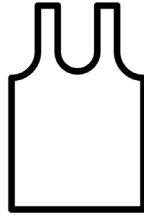
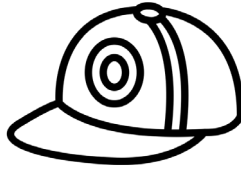

le pantalon/ the trousers

les chaussettes / the socks

la chaussure / the shoe

le short / the shorts

le caleçon / the underpants

le t-shirt / the t-shirt

la veste / the jacket

la casquette / the cap

les lunettes / the glasses

le maillot de corps / the undershirt

les tongs / the flipflops

le sac à dos / the backpack

le sac / the bag

le pull / the sweater

la robe / the dress

LES VÊTEMENTS COLORÉS / COLOURED CLOTHES

Colore les vêtements de la bonne couleur. /
Color the clothes in the right color.



Save the Children

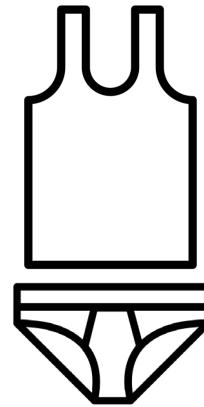
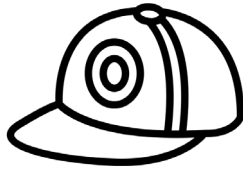
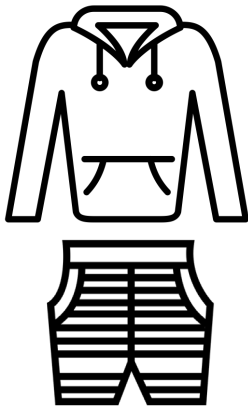

Le pull est jaune. / The sweater is yellow.
Les shorts sont rouges. / The shorts are red.
La casquette est bleue. / The cap is blue.

Le maillot de corps est bleu clair. / The undershirt is light blue.
Le caleçon est rose. / The underpants are pink.
Les chaussettes sont violettes. / The socks are purple.

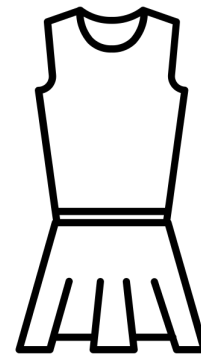
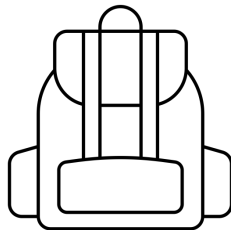
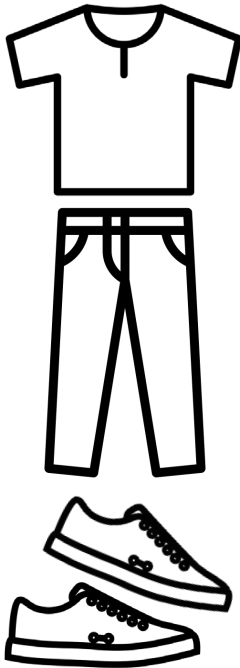

Le t-shirt est rouge. / The t-shirt is red.
Le pantalon est bleu. / The pants are blue.
Les chaussures sont vertes. / The shoes are green.
Le sac à dos est marron. / The backpack is brown.

La robe est orange. / The dress is orange.
Le sac est noir. / The bag is black.
Les tongs sont bleues. / The flipflops are blue.

Je m'appelle : / My name is:

Mon pantalon est: / My pants are:

Mon t-shirt est : / My t-shirt is:

Mon pull est : / My sweater is:

Ma veste est : / My jacket is:

Mes chaussures sont / My shoes are:

QUI HABITE OÙ ? / WHO LIVES WHERE?

Suis les lignes avec un crayon de couleur. /
Follow the lines with a coloured pencil.



Save the Children

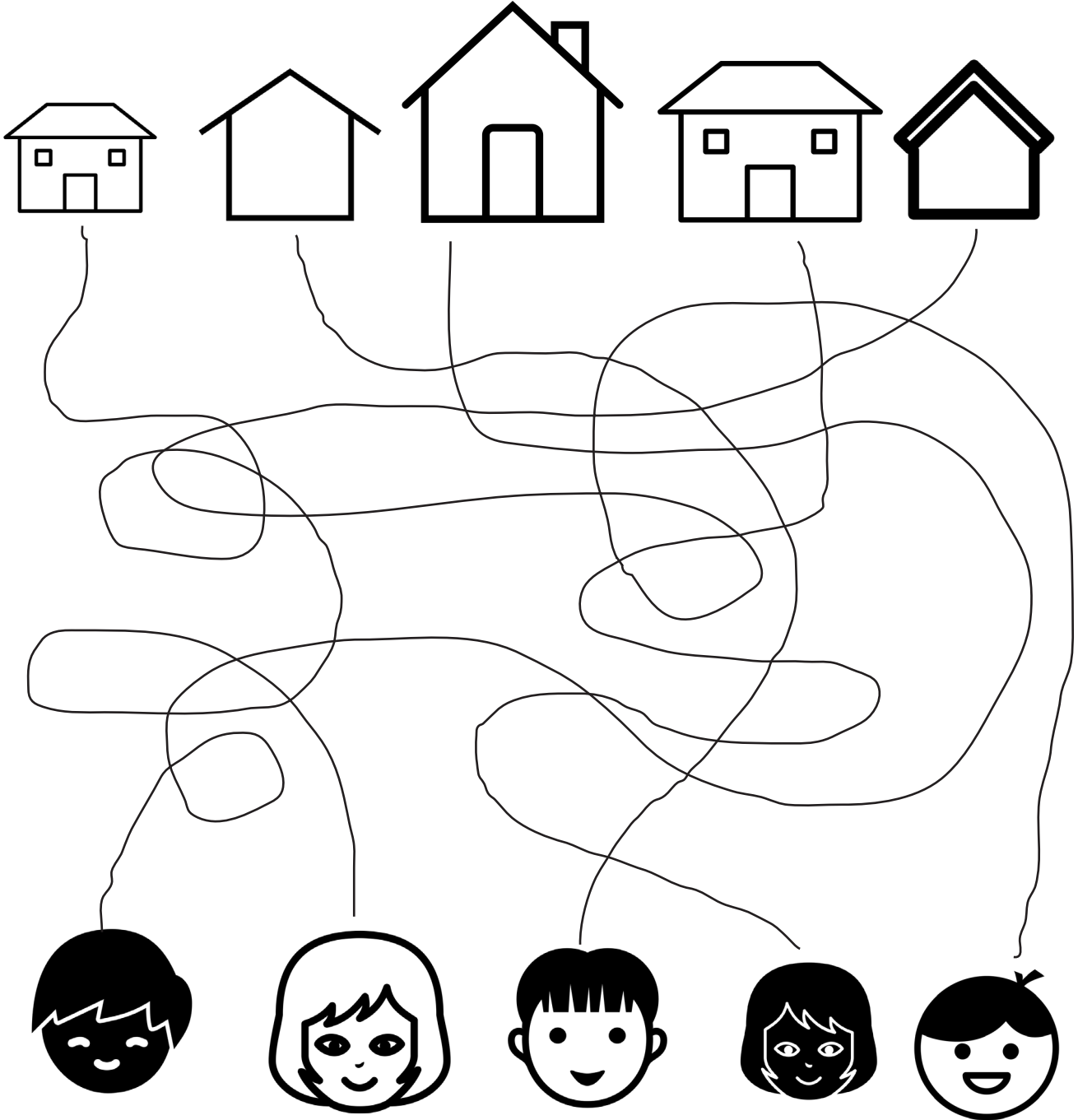

QUEL ANIMAL MANGE QUOI ? / WHICH ANIMAL EATS WHAT?

Dessine une ligne. / Connect with a line.



Save the Children



le lapin /
the rabbit

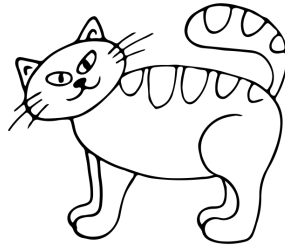

le chat /
the cat

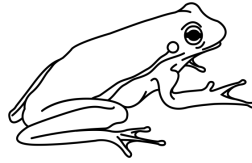

la grenouille /
the frog

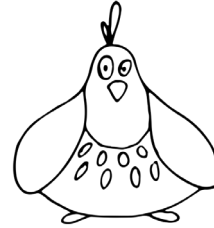

la poule /
the hen

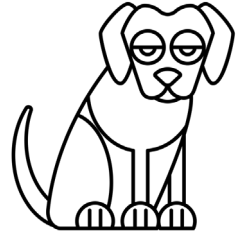

le chien /
the dog

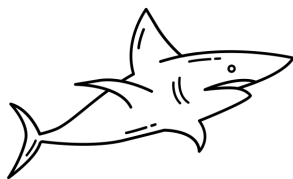
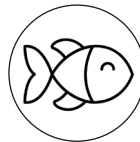
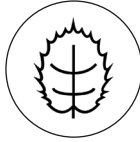

le requin /
the shark

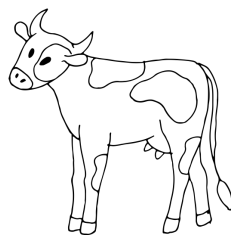

la vache /
the cow



la chenille /
the caterpillar

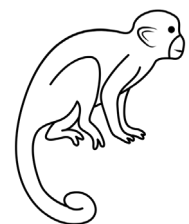

le singe /
the monkey

5 3 7 2 8 10 4 6 1 9

1 _____

10 _____

● ● =

● ● ● ● =

● =

● ● ● =

● ● ● ● ● =

● ● ● ● ● ● ● =

● ● ● ● ● ● ● ● ● ● =

● ● ● ● ● ● =

● ● ● ● ● ● ● ● ● =

● ● ● ● ● ● ● ● =

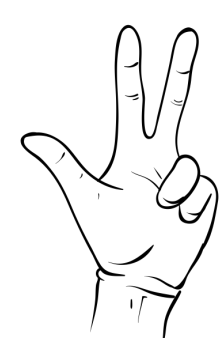

$7+1=$

$1+1=$

$2+2=$

$1+4=$

$1+3=$

$5+5=$

$2+5=$

$5+1=$

$1+3=$

$2+3=$

$3+3=$

$4+4=$

$4+4=$

$4+3=$

$7+2=$

$1+1=$

$7+1=$

$8+1=$

$9+1=$

$8+1=$

$9+1=$

$2+8=$

$2+8=$

$2+8=$

$1+3=$

$2+3=$

$4+3=$

$7+1=$

$1+7=$

$9+1=$

$3+3=$

$4+3=$

$6+3=$

$2+3=$

$2+3=$

$2+7=$

$1+4=$

$1+4=$

$7+1=$

$5+1=$

$5+3=$

$5+4=$

$3+7=$

$2+7=$

$3+1=$

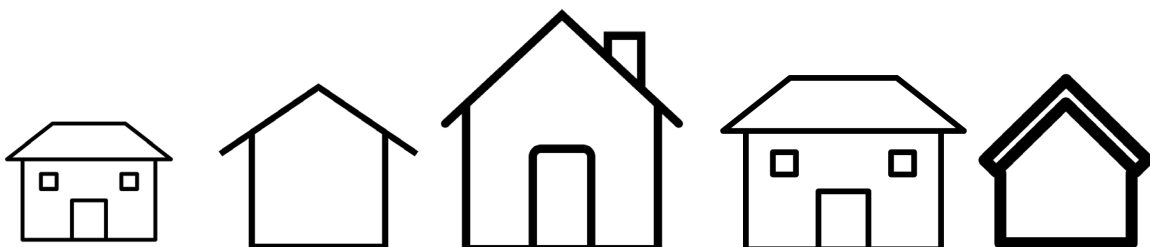

DE NOMBREUSES MAISONS COLOREES / MANY COLOURFUL HOUSES

Colorie les maisons de la bonne couleur. Résous l'équation. Exemple : si la solution est 5, utilise la couleur bleue. / Color the houses in the right color. Solve the math problem. Example: If the solution is 5, color the house in blue.

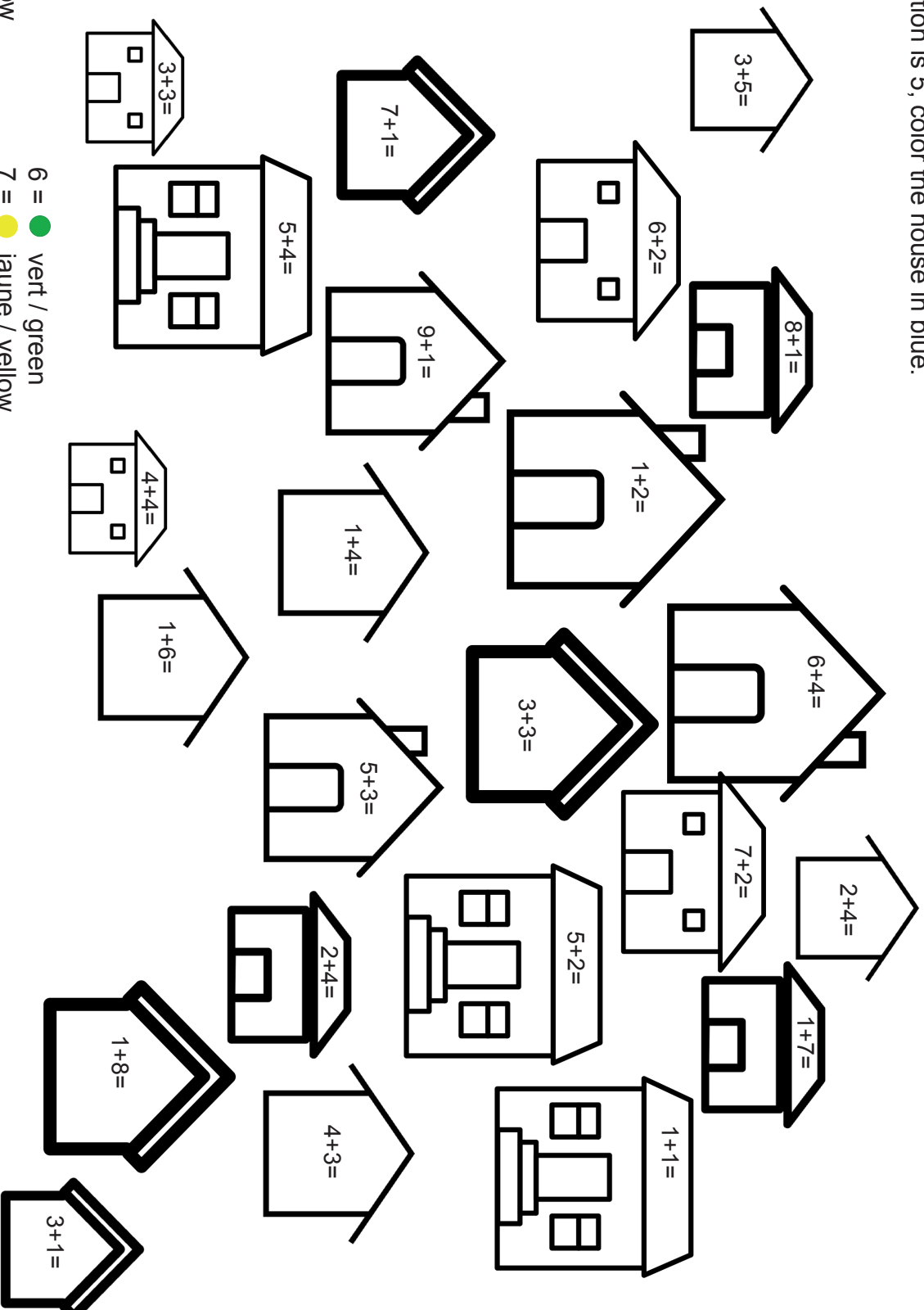

- 1 = rouge / red
- 2 = jaune / yellow
- 3 = violet / purple
- 4 = marron / brown
- 5 = bleu / blue

- 6 = vert / green
- 7 = jaune / yellow
- 8 = rose / pink
- 9 = orange / orange
- 10 = bleu / blue



Save the Children

PEINDRE DES MOTIFS / PAINTING PATTERNS

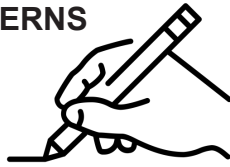

Save the Children

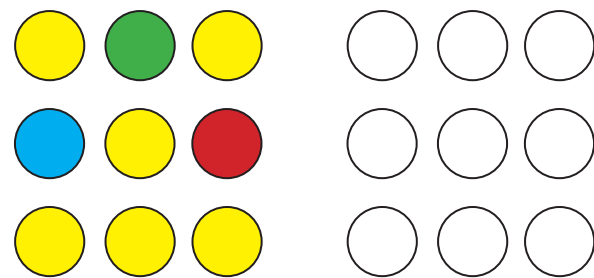
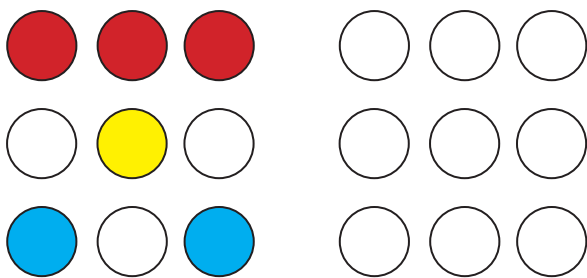
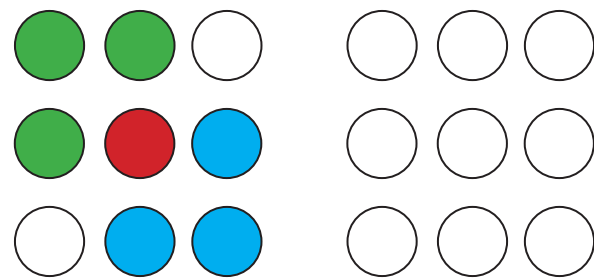
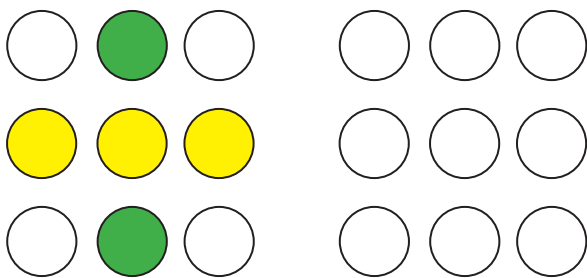
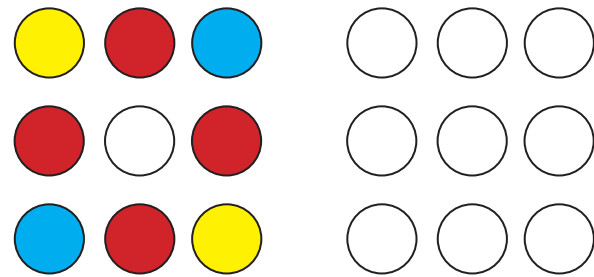
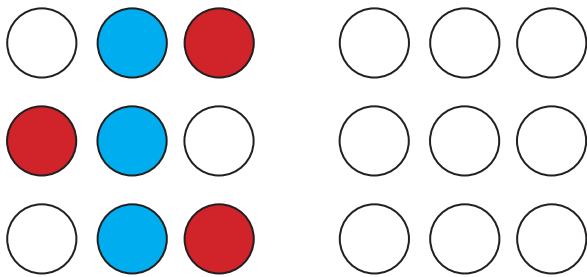
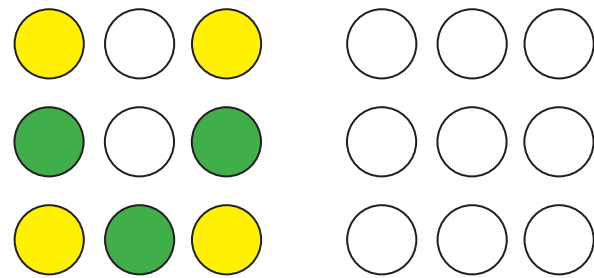
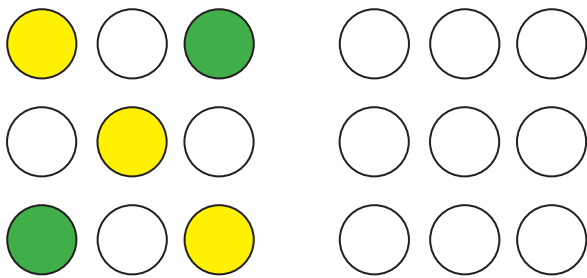
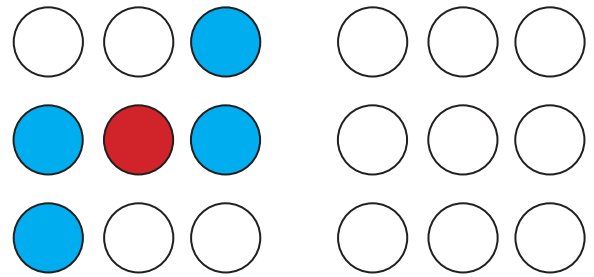
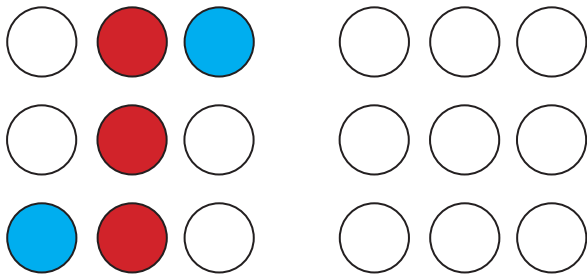

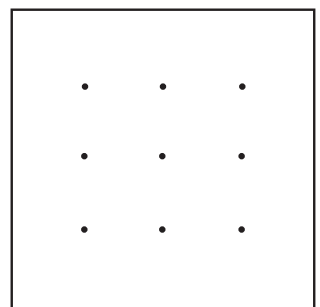
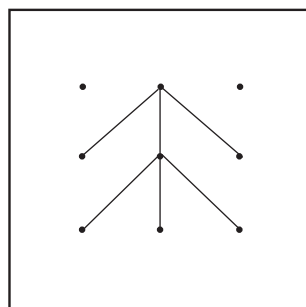
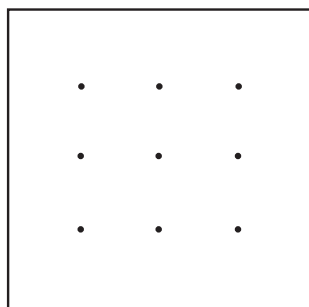
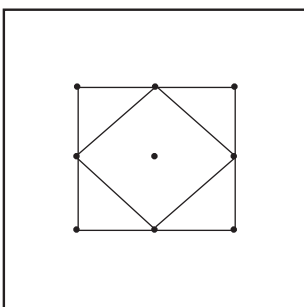
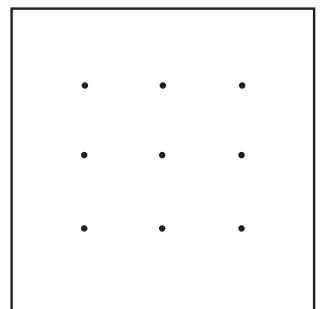
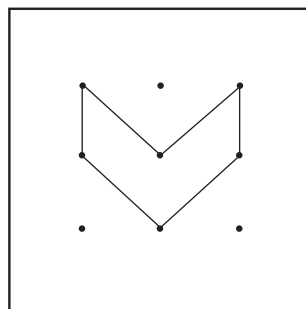
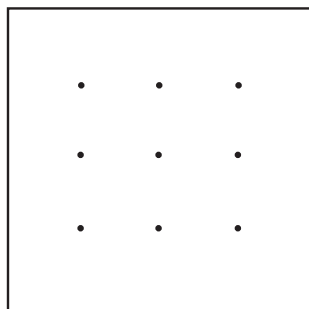
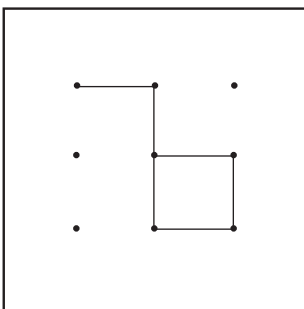
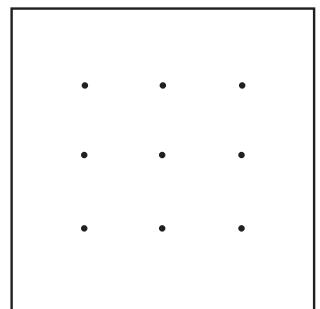
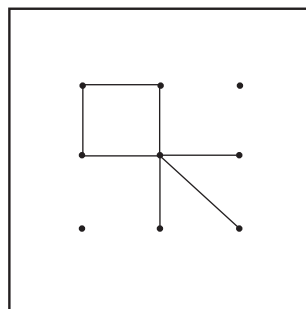
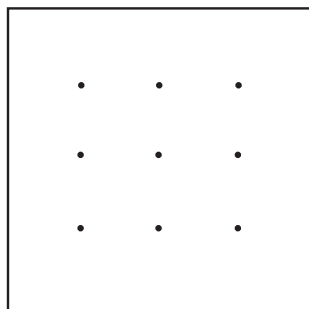
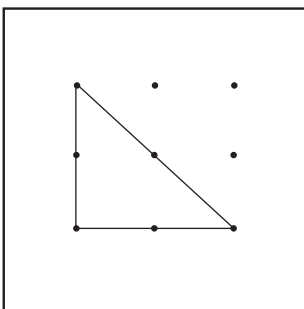
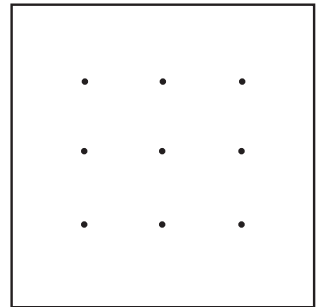
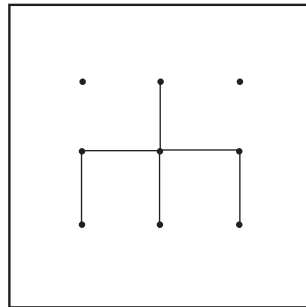
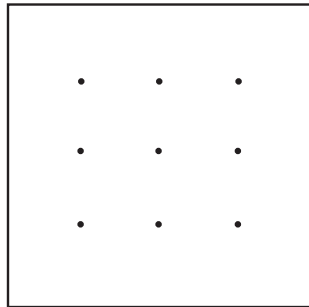
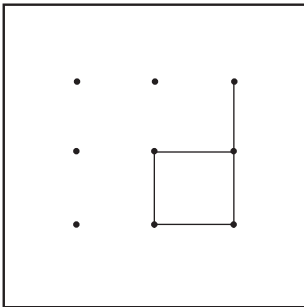
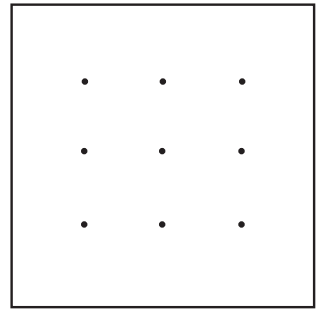
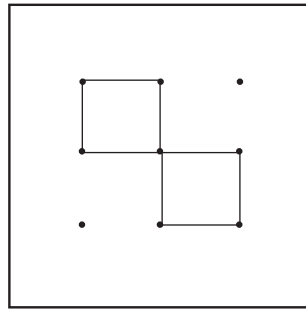
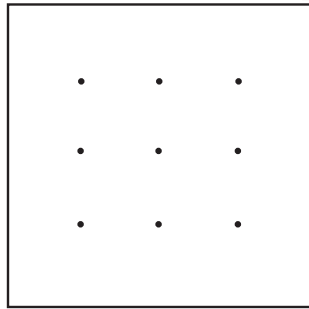
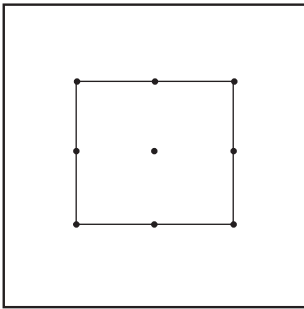
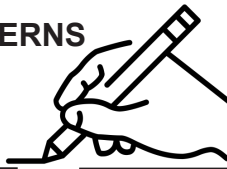

FRUIT OU LÉGUME ? / FRUIT OR VEGETABLE ?

Qu'est-ce qui va dans quel panier ? /

What goes in which basket?



Save the Children

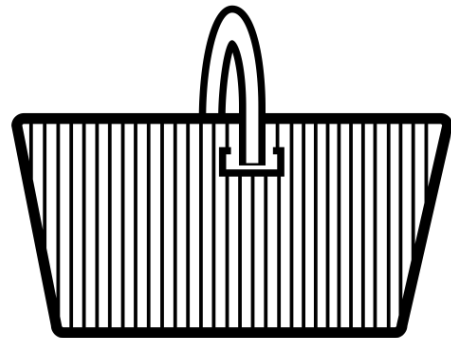
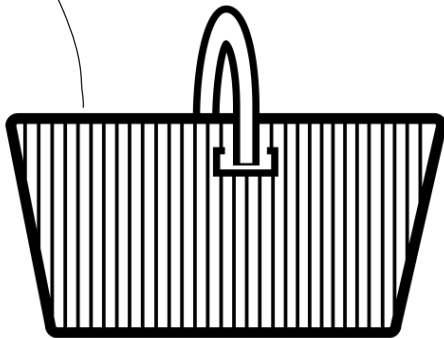
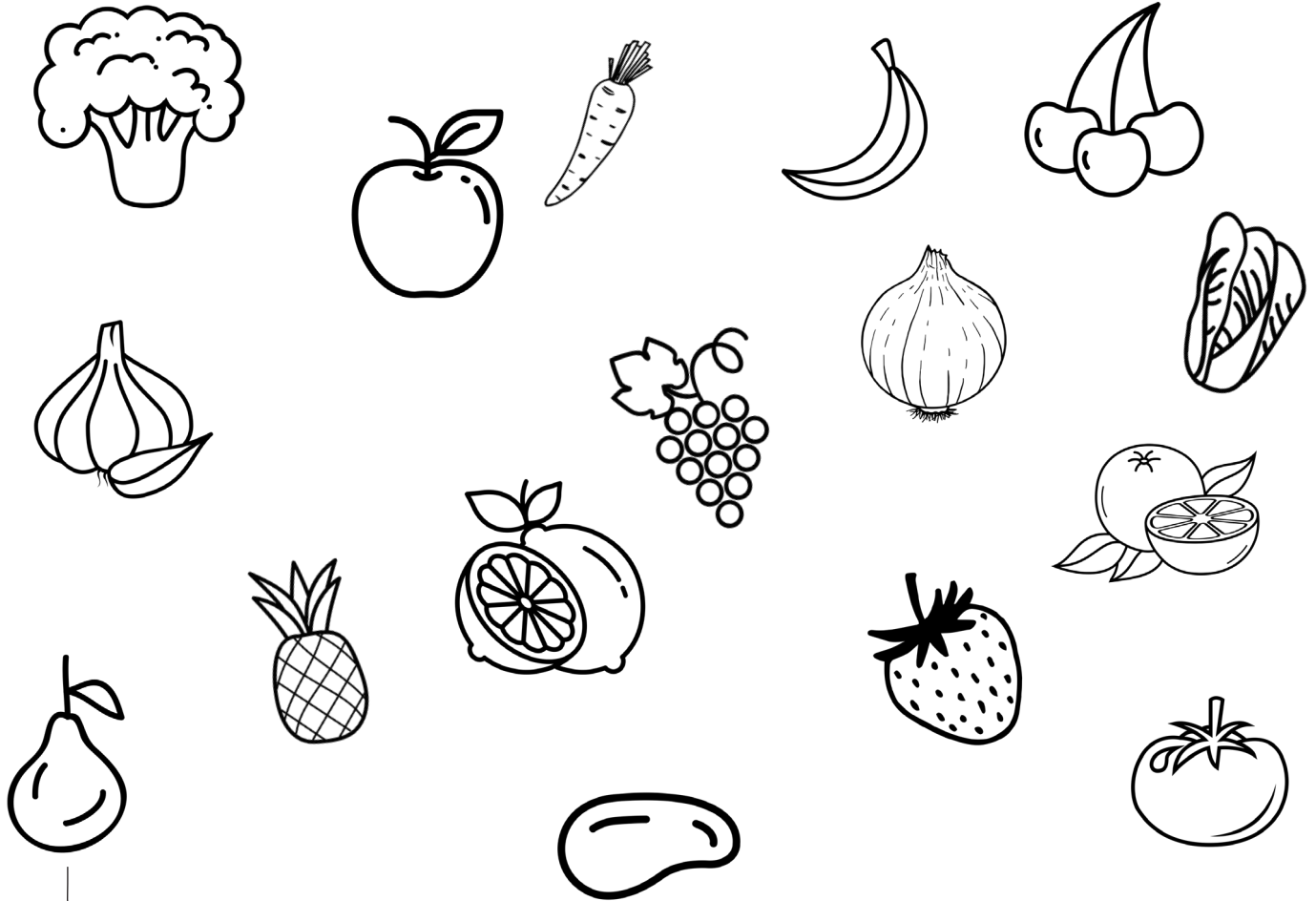

Colorie les fruits ou les légumes de la bonne couleur. /
Color the fruit or vegetables in the right color.



**COMMENT S'APPELLENT CES FRUITS ET LÉGUMES ? /
WHAT ARE THESE VEGETABLES AND FRUITS CALLED?**

Écris le bon mot sous la bonne image. / Write the right word to the picture.



Save the Children



le brocoli

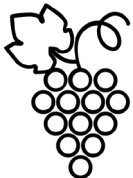
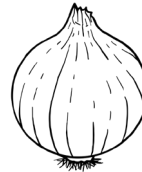
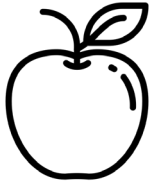
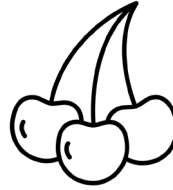

la salade / the salad

la fraise / the strawberry

l'orange / the orange

la pomme de terre / the potato

l'oignon / the onion

la cerise / the cherry

l'ail / the garlic

le citron / the lemon

la banane / the banana

le brocoli / the broccoli

la pomme / the apple

la poire / the pear

l'ananas / the pineapple

le raisin / the grape

la carotte / the carrot

la tomate / the tomato

LE CORPS / THE BODY

Sais-tu comment sont appelées ces parties du corps ?

Écris le bon mot sous la bonne image. /

Do you know what these body parts are called?

Write the right word under the right picture.



Save the Children



l'oreille

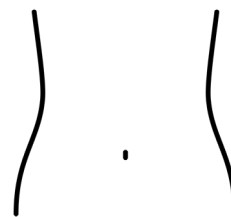
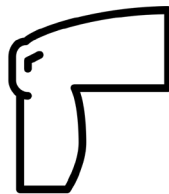
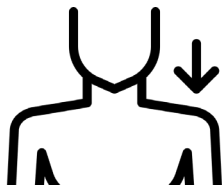
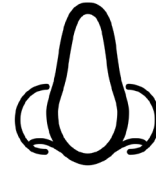

le genou / the knee

l'oreille / the ear

le pied / the foot

la jambe / the leg

le bras / the arm

les cheveux / the hair

la main / the hand

l'épaule / the shoulder

les dents / the teeth

la tête / the head

la bouche / the mouth

le doigt / the finger

le ventre / the belly

l'œil / the eye

le nez / the nose

C'EST MOI : / THAT'S ME:

Dessine-toi. Quelle chemise portes-tu ?

De quelle couleur sont tes cheveux ? /

Draw yourself. What shirt are you wearing?

What color is your hair?



Save the Children



DESSINER DES VISAGES / DRAWING FACES



A collection of 18 circular face templates for drawing. Some faces are partially drawn with simple features, while others are blank for the user to complete.

- Top row: A smiling face with two dots for eyes and a simple smile; a face with a tongue sticking out; a face with wide eyes and a wavy mouth.
- Second row: A face with a simple downward-curving mouth; two blank faces; a face with four teardrops.
- Third row: A blank face; a face with wide eyes and an open oval mouth; a face with a single dot in the center; a blank face.
- Fourth row: A face with large eyes, long eyelashes, and a wide smile; a blank face; a blank face.
- Fifth row: A blank face; a face with two hearts for eyes; a face with closed eyes and long eyelashes.

TÊTE, ÉPAULES, GENOUX ET PIEDS / HEAD, SHOULDERS, KNEES AND TOES

Chanson avec mouvements / Song with movements



Tête, épaules, genoux et pieds, genoux et pieds.
Tête, épaules, genoux et pieds, genoux et pieds.
J'ai deux yeux, deux oreilles, une bouche et un nez.
Tête, épaules, genoux et pieds, genoux et pieds.

English:

Head, shoulders, knees and toes, knees and toes,
head, shoulders, knees and toes, knees and toes,
eyes, ears, mouth, nose,
head, shoulders, knees and toes, knees and toes.

Youtube: <https://www.youtube.com/watch?v=vyTNuVCdUzw&t=41s>

Voici comment procéder :

Pendant que tu chantes, tu touches les parties du corps mentionnées. Quand tu chantes « tête », tu touches ta tête, etc. Tu peux chanter la chanson plusieurs fois pour apprendre la séquence des mouvements. Tu peux commencer la chanson lentement, puis accélérer jusqu'à ce que plus personne ne puisse suivre.

That's how it's done:

While singing, touch the parts of the body you sing about. When you sing „head“, touch your head and so on. You can sing the song several times so that you learn the sequence of movements. You can start the song slowly, then increase the speed until it is so fast that nobody can follow anymore.

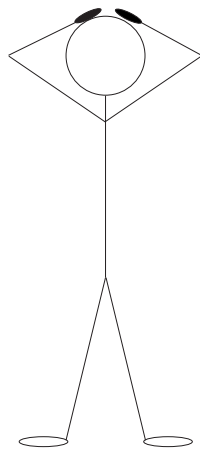

TÊTE /
HEAD

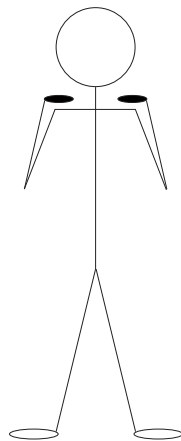

ÉPAULES /
SHOULDERS

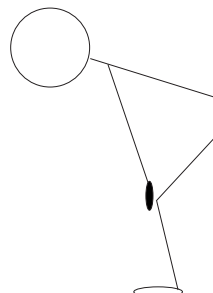

GENOUX /
KNEES

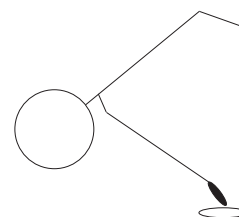

PIEDS /
TOES



YEUX /
EYES



OREILLES /
EARS



NEZ /
NOSE



BOUCHE /
MOUTH

DADDY FINGER

Chanter avec la main / Singing with the hands



Daddy finger, daddy finger, where are you?
Here I am, here I am
How do you do?
Mommy finger, mommy finger, where are you?
Here I am, here I am
How do you do?
Brother finger, brother finger, where are you?
Here I am, here I am
How do you do?
Sister finger, sister finger, where are you?
Here I am, here I am
How do you do?
Baby finger, baby finger, where are you?
Here I am, here I am
How do you do?



Youtube: http://kids-songs.tv/the_finger_family

Voici comment procéder :

Lever le pouce : Chanter « Daddy finger, daddy finger, where are you ? ». Strophe entière.
Lever l'index : Chanter « Mommy finger, mommy finger, where are you ? ». On continue avec le majeur : « Brother finger ... » La chanson continue jusqu'à ce que les cinq doigts aient été levés et que la main soit grande ouverte.

That's how it's done:

Thumbs up, sing „daddy finger, daddy finger, where are you?“ The whole verse.
Forefinger up. Sing: „mommy finger, mommy finger, where are you?“. The whole verse. Continue with your middle finger and sing: „brother fingers...“ Continue the song until all five fingers are up and your whole hand is open.

IF YOU'RE HAPPY AND YOU KNOW IT

Chanson avec mouvements / Song with movements



1.
If you're happy and you know it, clap your hands.
If you're happy and you know it, clap your hands.
If you're happy and you know it
and you really want to show it,
If you're happy and you know it, clap your hands.

2.
If you're happy and you know it, slap your sides.
If you're happy and you know it, slap your sides.
If you're happy and you know it
and you really want to show it,
If you're happy and you know it, slap your sides.

3.
If you're happy and you know it, stomp your feet.
If you're happy and you know it, stomp your feet.
If you're happy and you know it
and you really want to show it,
If you're happy and you know it, stomp your feet.

4.
If you're happy and you know it, snap your fingers.
If you're happy and you know it, snap your fingers.
If you're happy and you know it
and you really want to show it,
If you're happy and you know it, snap your fingers.

5.
If you're happy and you know it, sniff your nose.
If you're happy and you know it, sniff your nose.
If you're happy and you know it
and you really want to show it,
If you're happy and you know it, sniff your nose.

2.
If you're happy and you know it, shout "We are".
If you're happy and you know it, shout "We are".
If you're happy and you know it
and you really want to show it,
If you're happy and you know it, shout "We are".

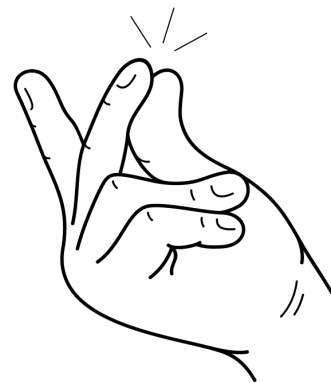
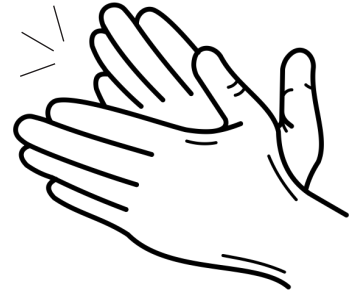

http://www.falleri.ch/index.php?option=com_content&view=article&id=141:if-youre-happy

Voici comment procéder :

On effectue un certain mouvement à chaque strophe.

« If you're happy and you know it, clap your hands. » Frapper dans les mains.

« If you're happy and you know it, stomp your feet. » Taper sur le sol avec le pied, etc.

À la fin de la chanson, la séquence des mouvements peut être répétée à grande vitesse.

On chante ensuite :

If you're happy and you know it, clap your hands, slap your sides, stomp your feet, snap your fingers, sniff your nose, shout « we are ». If you're happy ...

That's how it's done:

With each verse, you make a movement.

„If you're happy and you know it, clap your hands.“ Clap your hands.

„If you're happy and you know it, stomp your feet.“ Stomp your feet on the floor etc.

At the end of the song, you can repeat all the movements quickly one after the other. You then sing: „If you're happy and you know it, clap your hands, slap your sides, stomp your feet, snap your fingers, sniff your nose, shout „we are“. If you're happy...“

BONJOUR SOLEIL / GOOD MORNING, SUN

Exercices physiques sur une feuille de papier.

Garde tes pieds sur la feuille, sinon tu vas tomber. /

Physical exercises on a sheet of paper.

Keep your feet on the paper or you will fall.



Save the Children

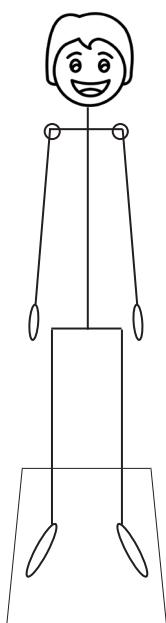
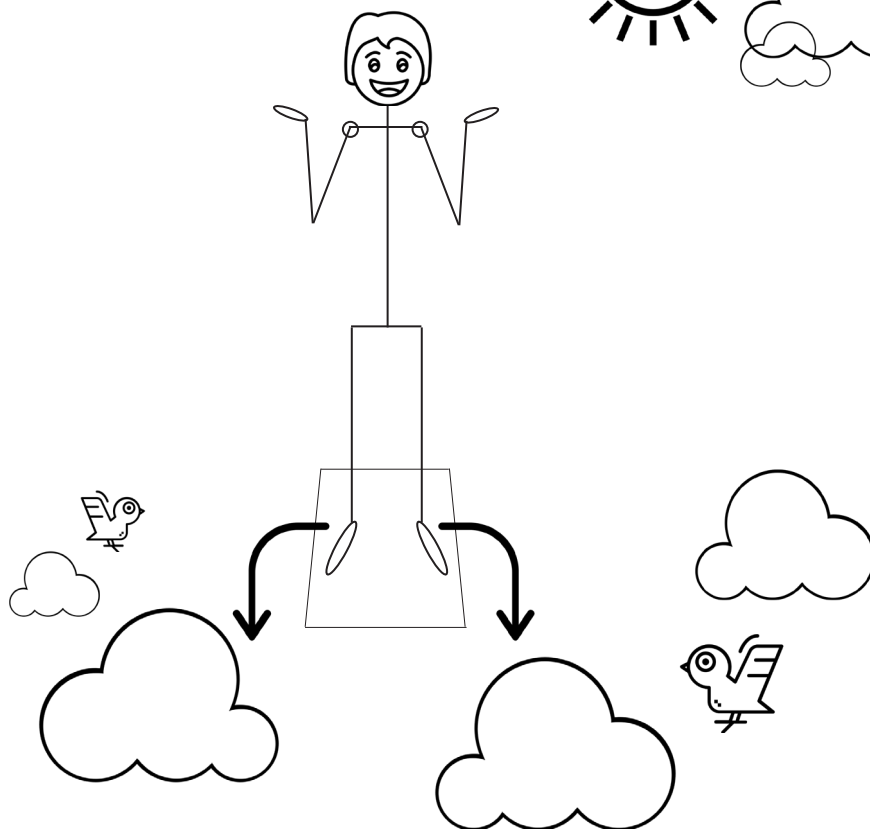
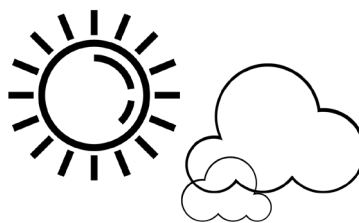
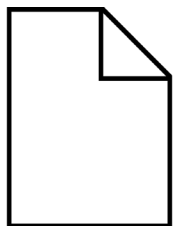

1.

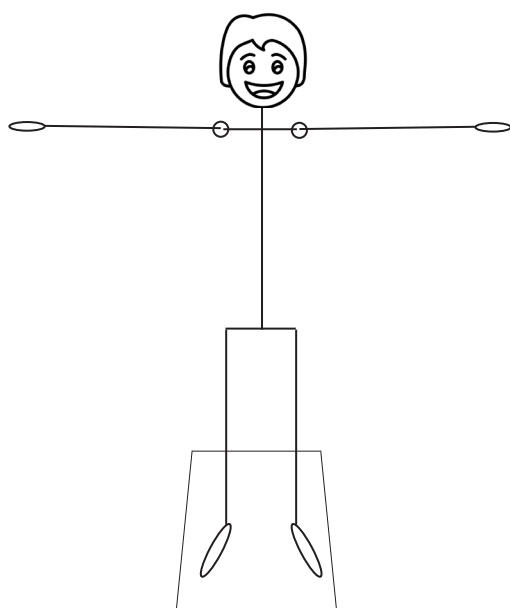

2.

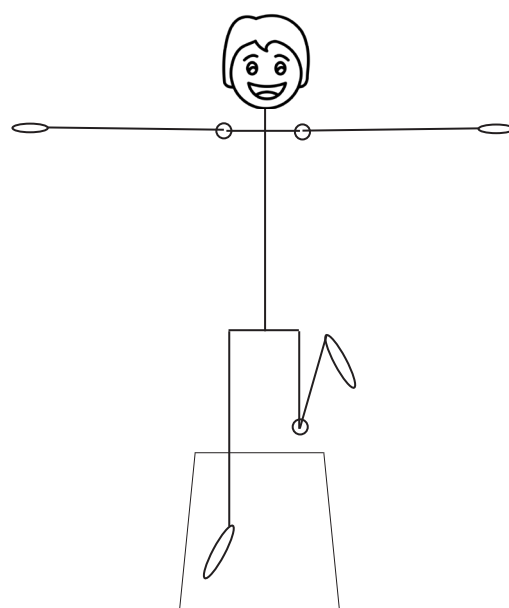

3.

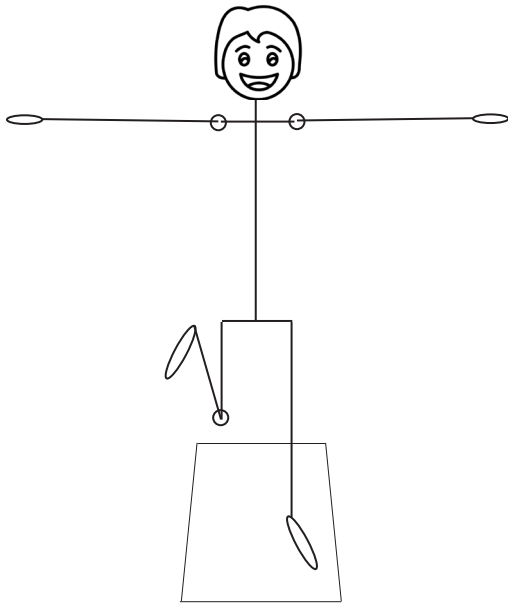

4.

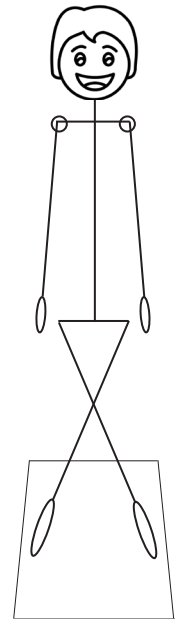
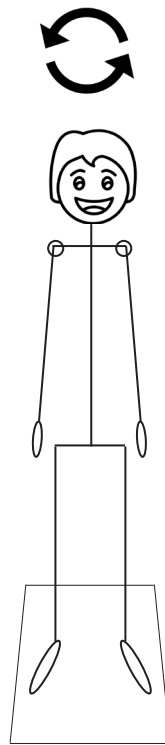

6.

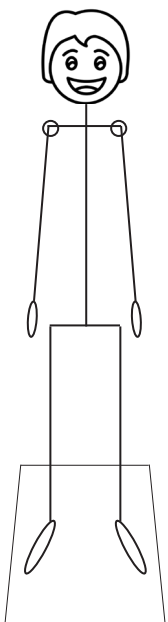

7.

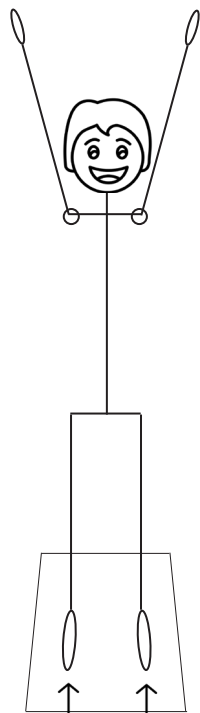

8.

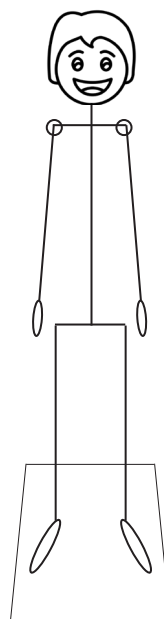

9.

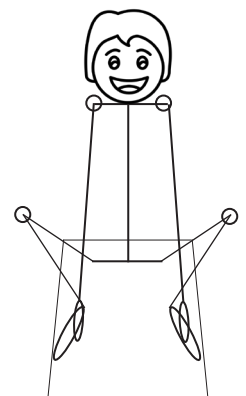

10.

LE MORPION / TIC TAC TOE

Qui gagne ?



Save the Children

Jeu pour deux. Une personne dessine un cercle, l'autre personne une croix ; toujours en alternance. Le premier qui obtient une rangée de ses symboles gagne. / Who will win? Game for two.

One person draws a circle, the other person a cross, always alternating. Whoever gets a row of his symbols first, wins.

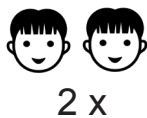

○	×	
○	×	○
×	×	○



		○
	○	
○		



×	×	×



JEU DE GÉOGRAPHIE (2-5 joueurs)



Pour ce jeu, vous n'avez besoin que de papier et de stylos. Vous pouvez dessiner la grille vous-même sur le papier. Une personne nomme une lettre, par exemple A. Puis chacun doit écrire un mot qui commence par cette lettre sous chaque colonne (catégorie). La personne qui a trouvé un mot pour toutes les catégories le plus vite dit : « stop !! ». Les autres doivent poser leurs stylos. Tout le monde dit ses mots. Pour chaque mot correct, il y a un point. Puis une autre personne dit une nouvelle lettre et le jeu recommence.

GEOGRAPHY GAME (2-5 players)

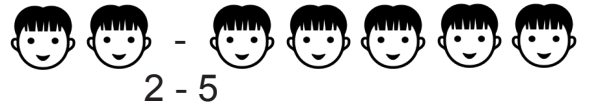

This game requires only paper and pens. You can draw the grid yourself on paper. One person names a letter, for example A. Then, everybody must write down a word for each category that begins with that letter. The person who has found a word for each category first, says stop. The others have to put down their pens. Everyone says their words. For every correct word, there is a point. Then another person says a new letter and the game starts all over again.

Lettres / Letters	Nom / Name	Pays / Country	Nourriture / Food	Points / Points
A	Ahmed	Australie	Abricot	A	A	3
Points / Points Somme / Total						_____

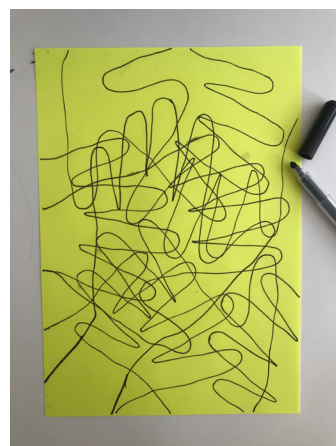
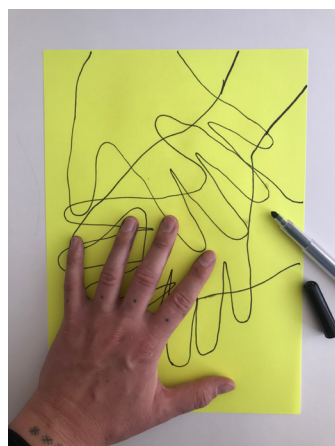

**PLIER UN CHAPEAU EN PAPIER
/ FOLDING A PAPER HAT**

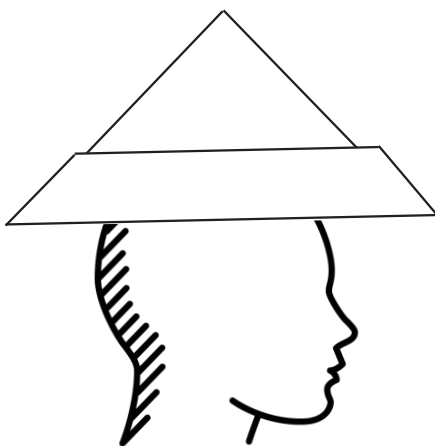
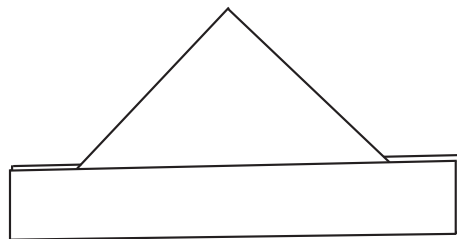
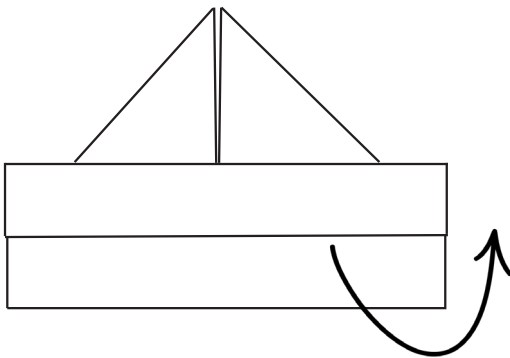
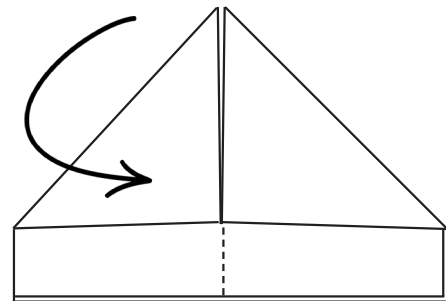
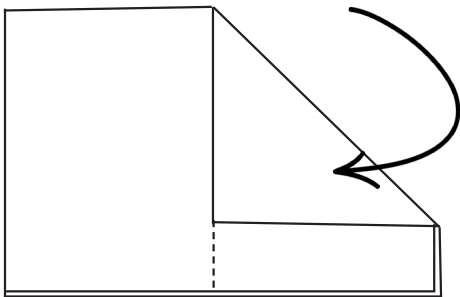
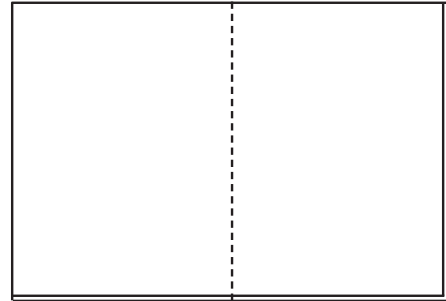
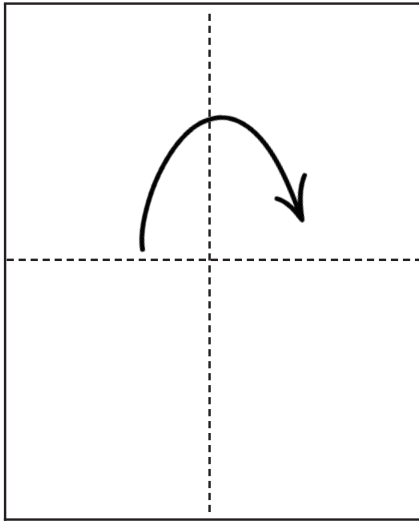

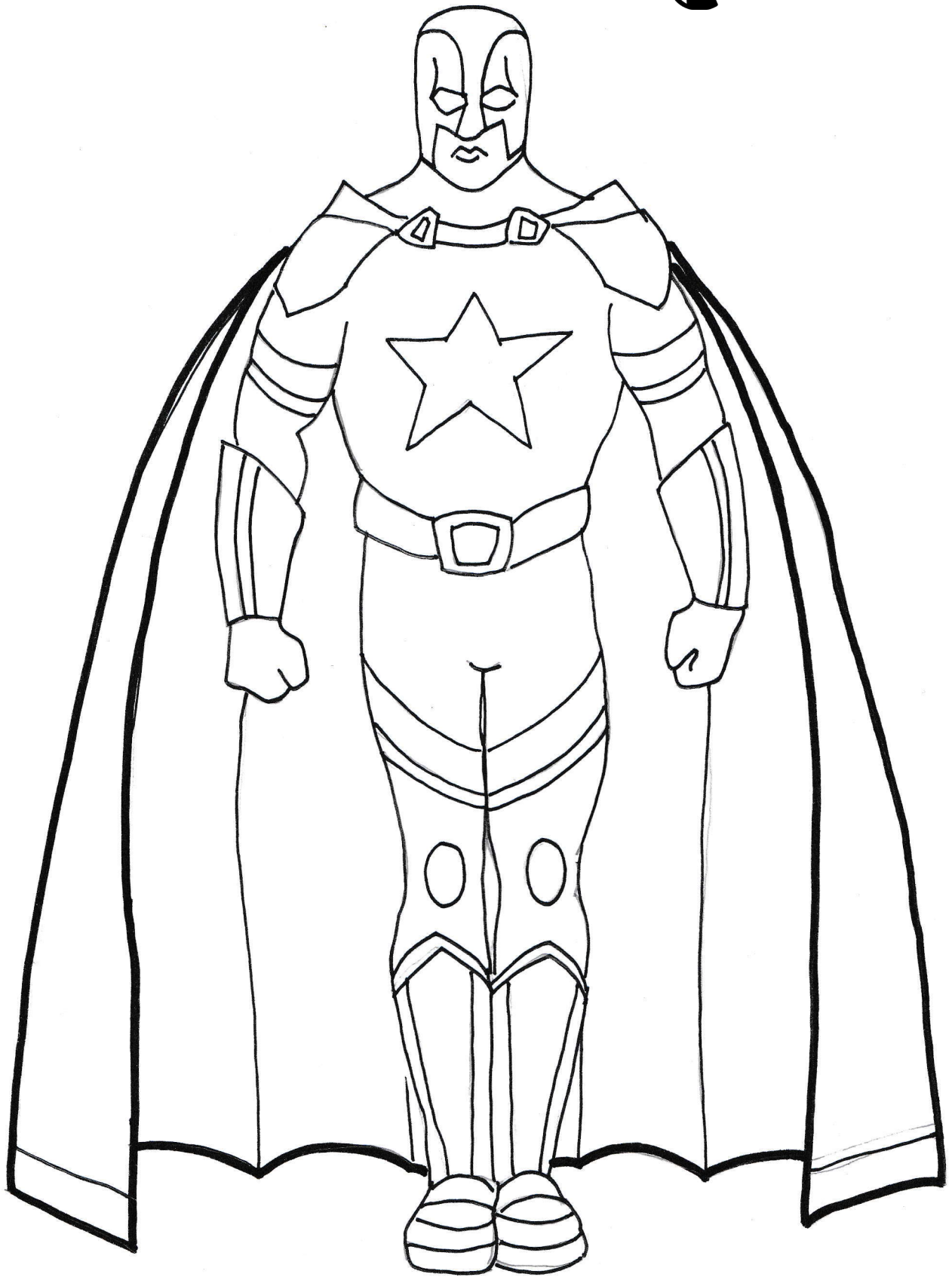

MON NOM EST : / MY NAME IS:

JE SUIS UN SUPER-HÉROS / I'M A SUPERHERO



MON NOM EST : / MY NAME IS:

JE SUIS UNE SUPER-HÉROÏNE / I'M A SUPERHEROINE

DESSINER DES MOTIFS /
DRAWING PATTERNS

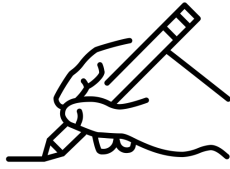

Save the Children

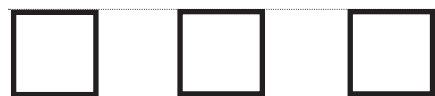
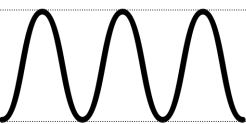
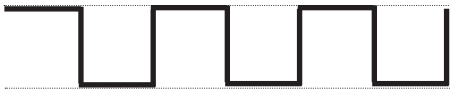

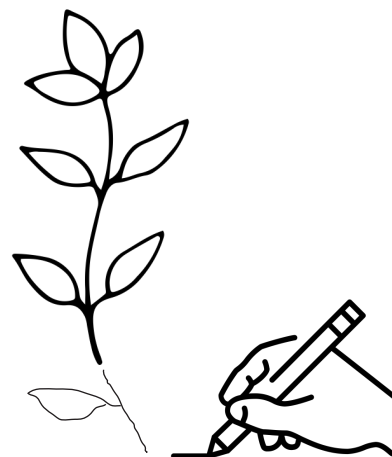
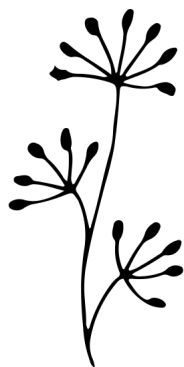

DESSINER / DRAWING

Remplis les formes. / Fill the forms.



Save the Children

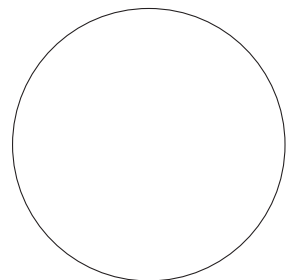
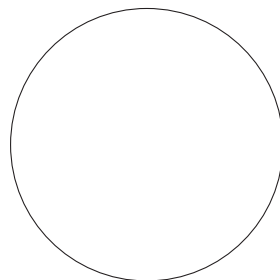
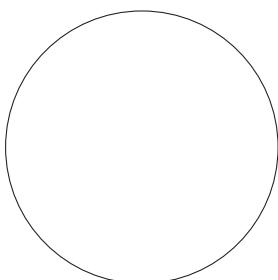
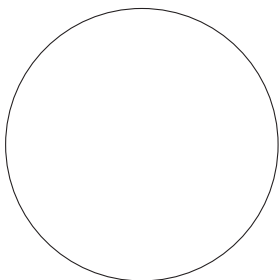
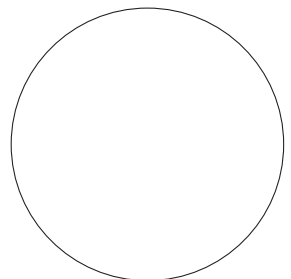
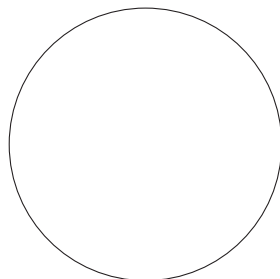
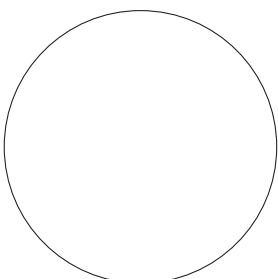
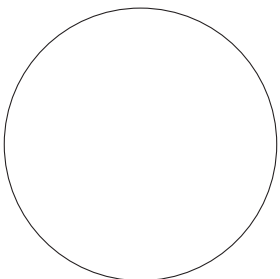
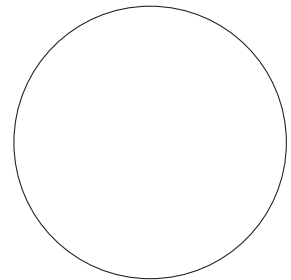
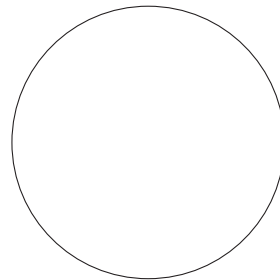
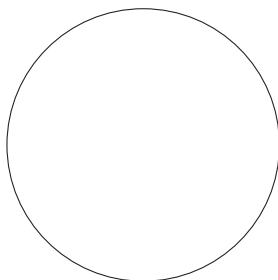
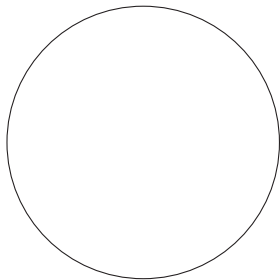
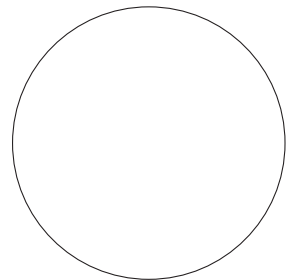
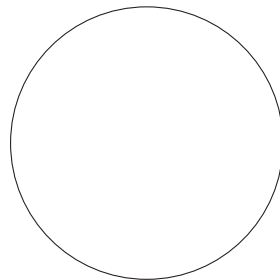
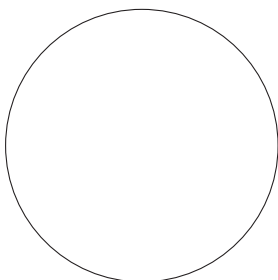
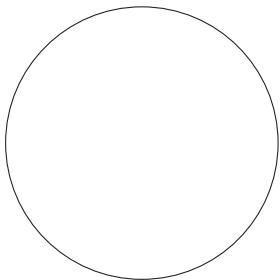
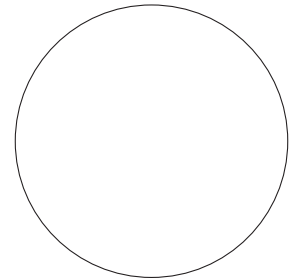
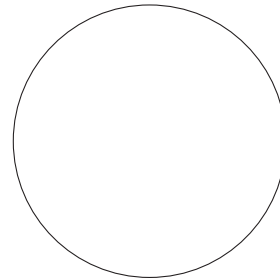
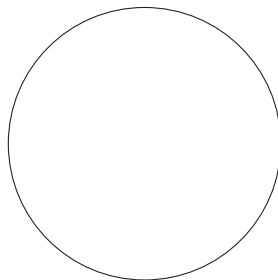
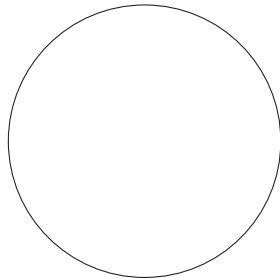
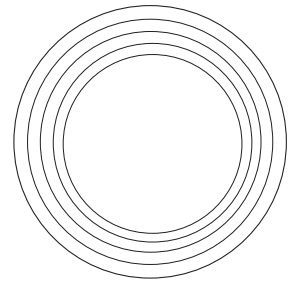
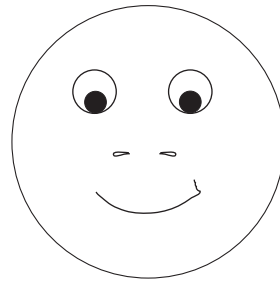
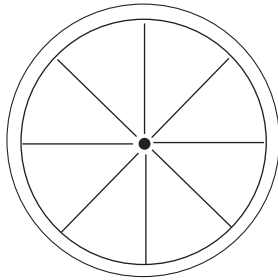
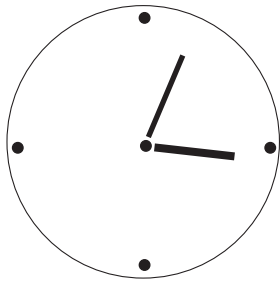

DESSINER / DRAWING

Remplis les formes. / Fill the forms.



Save the Children

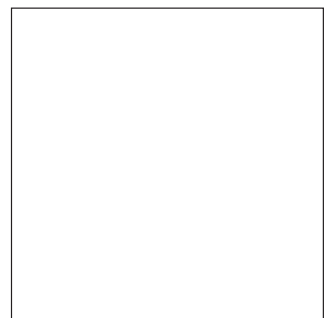
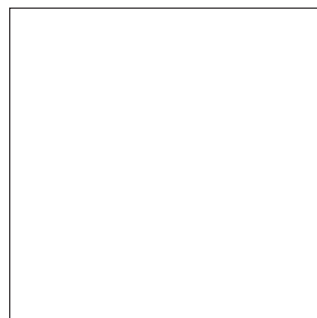
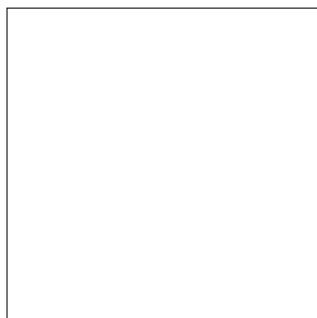
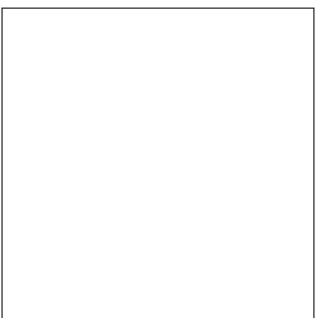
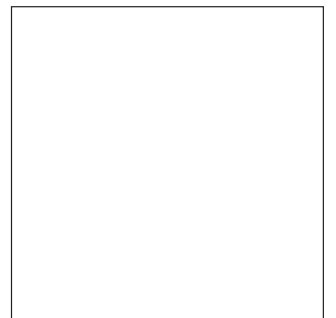
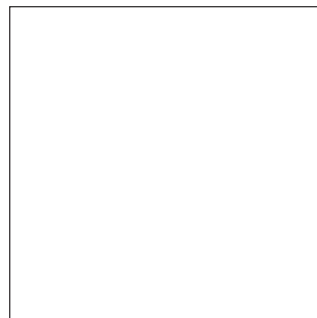
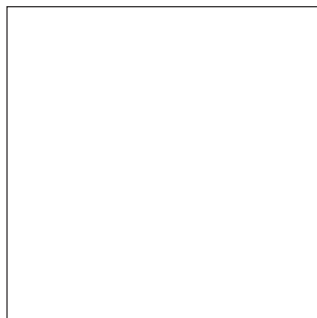
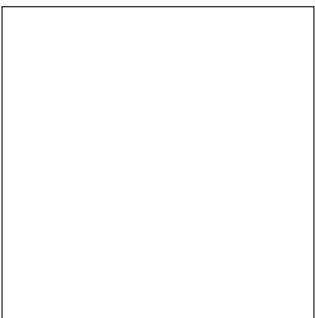
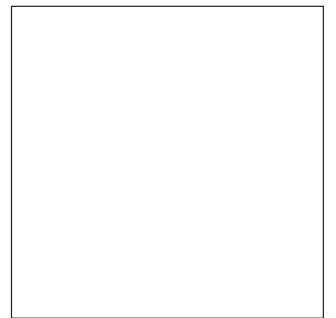
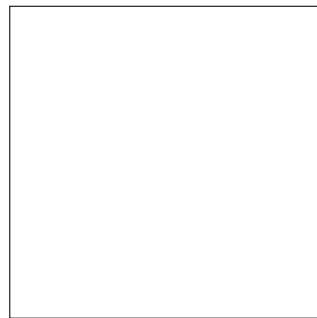
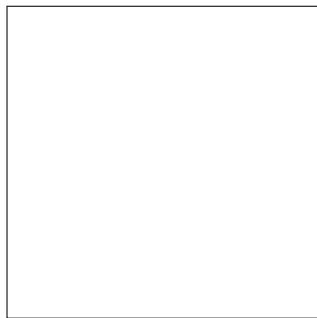
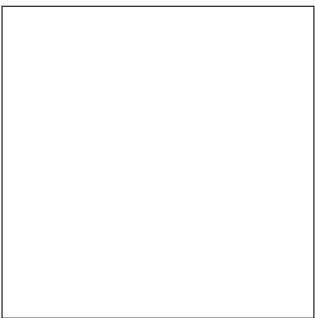
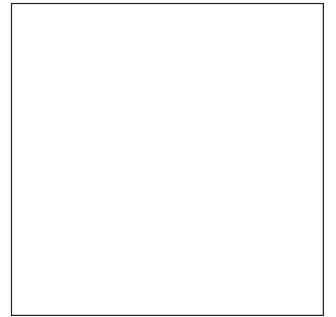
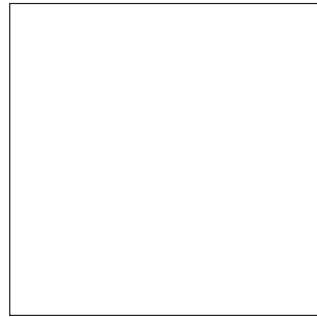
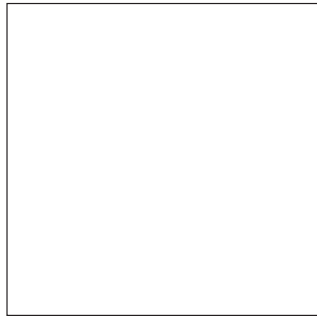
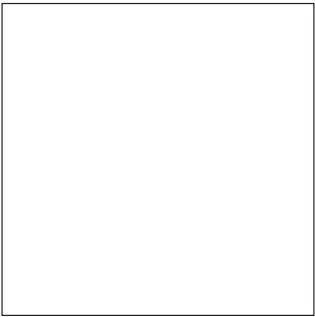
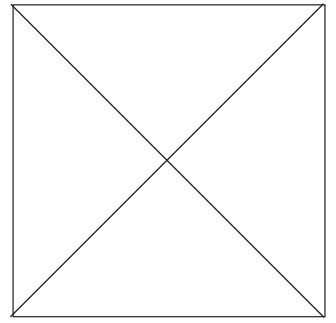
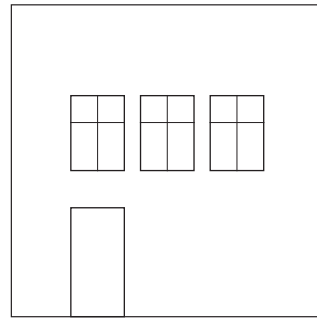
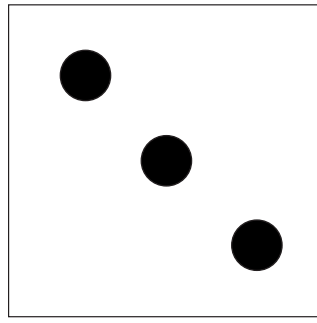
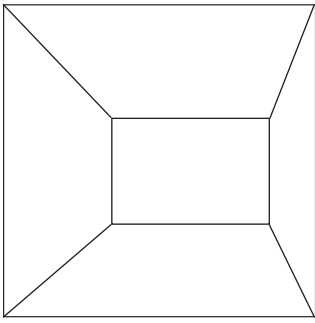

PEINDRE UN MANDALA
/ PAINTING A MANDALA

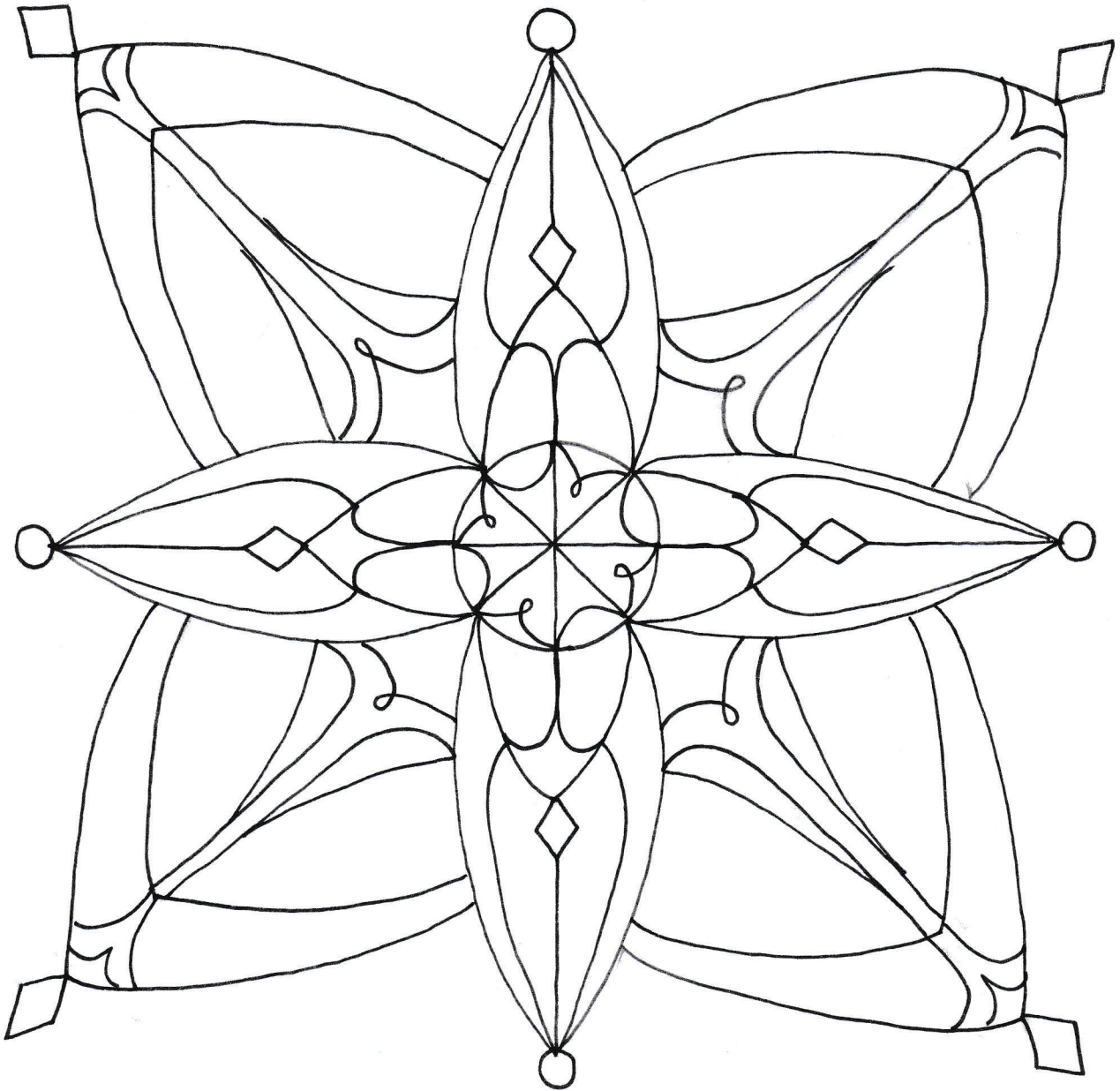

**COPIER UN MANDALA
/ COPYING A MANDALA**

Termine le dessin du mandala. /
Finish drawing the mandala.



Save the Children

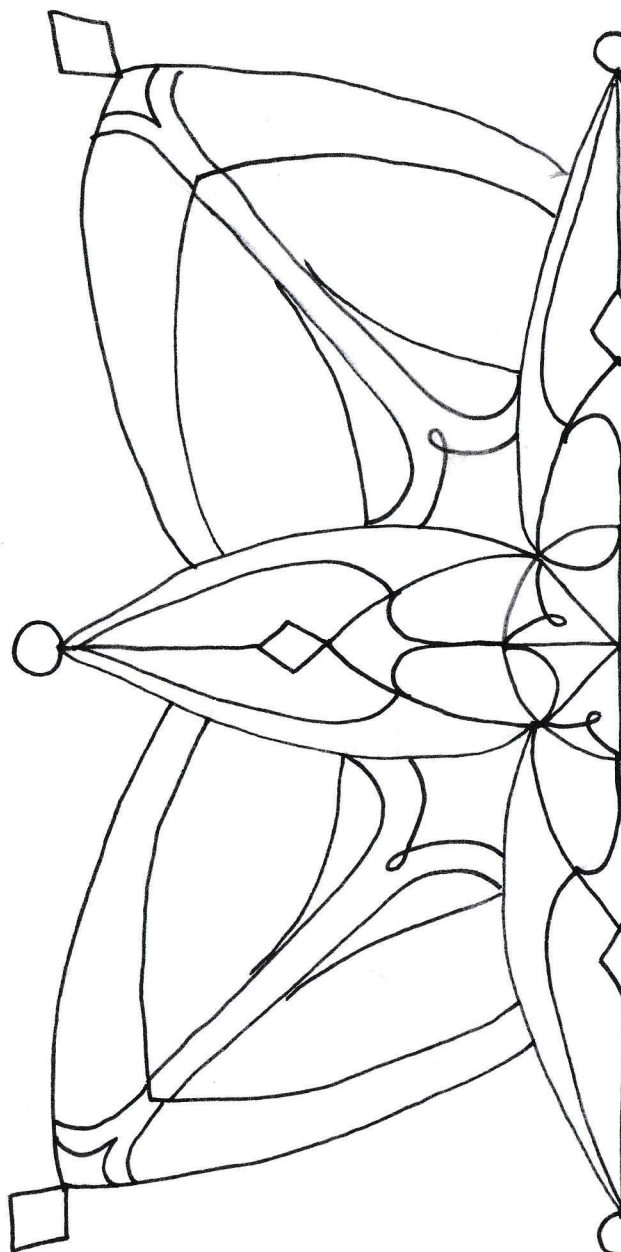

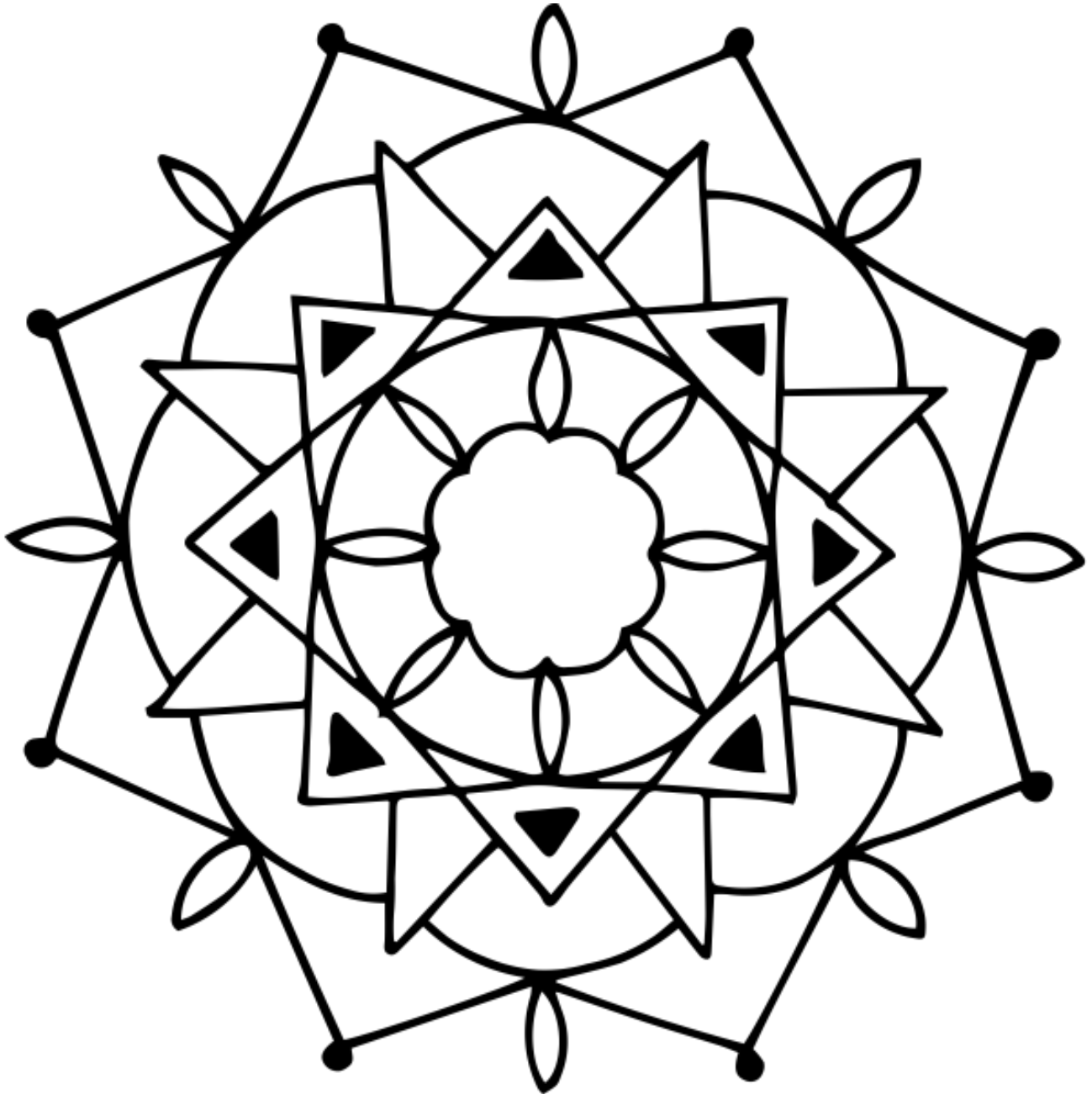

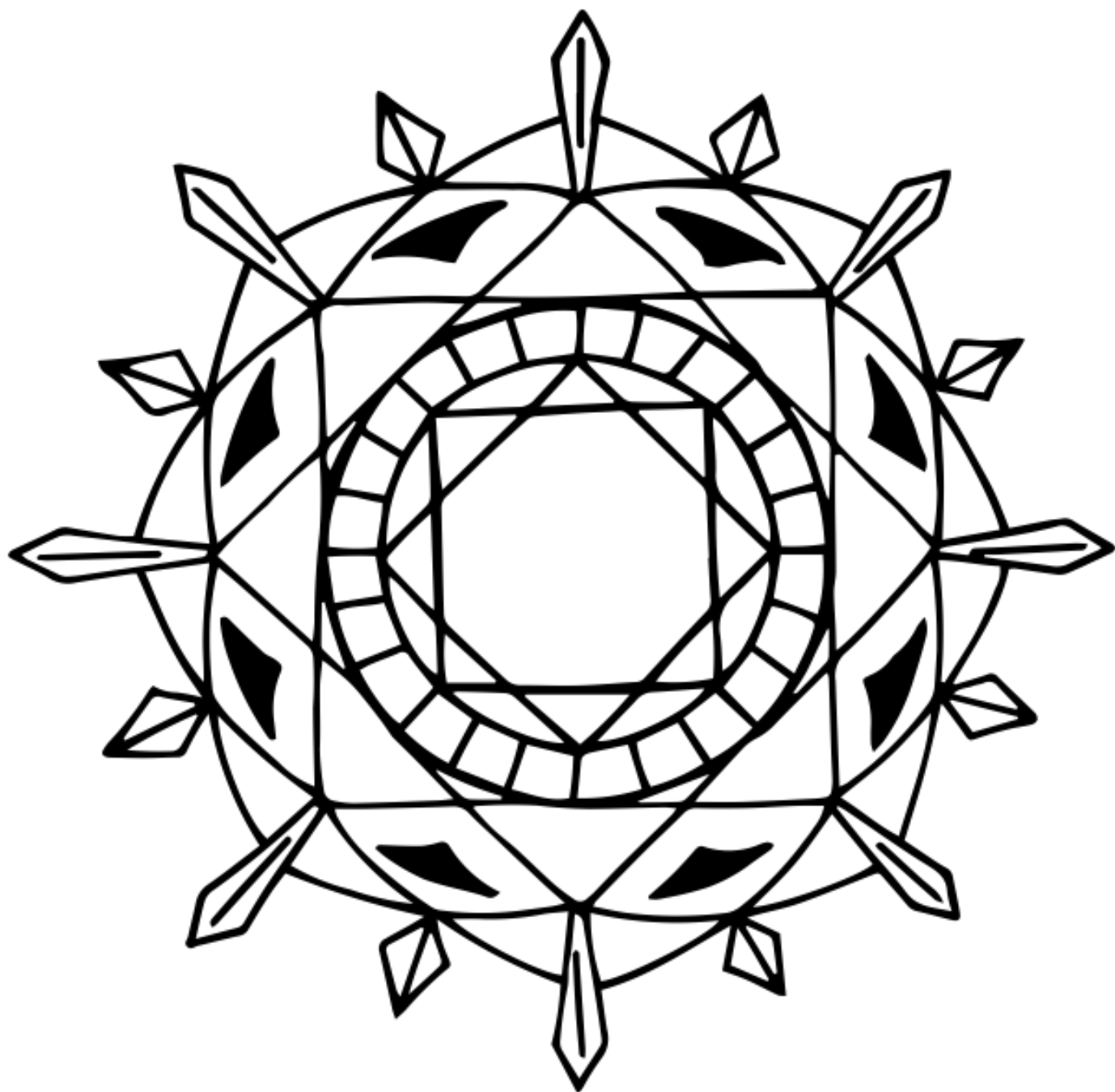

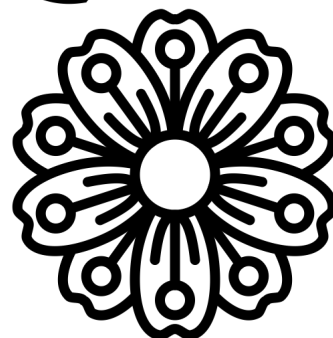
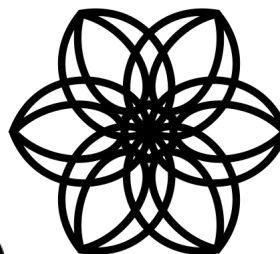
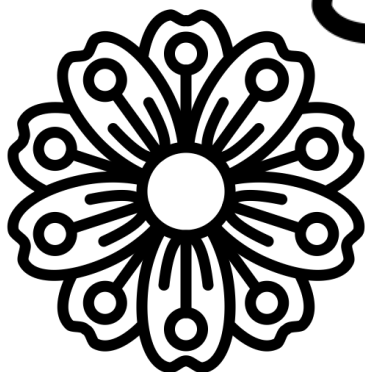
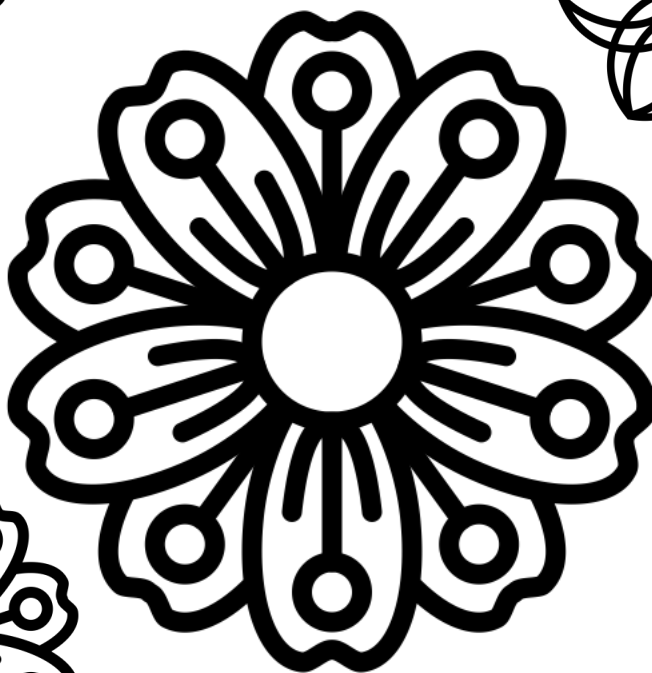
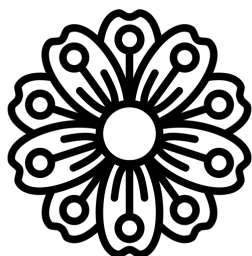
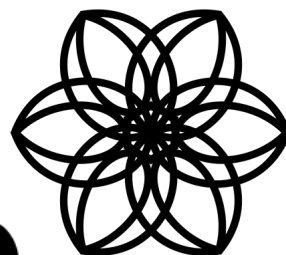

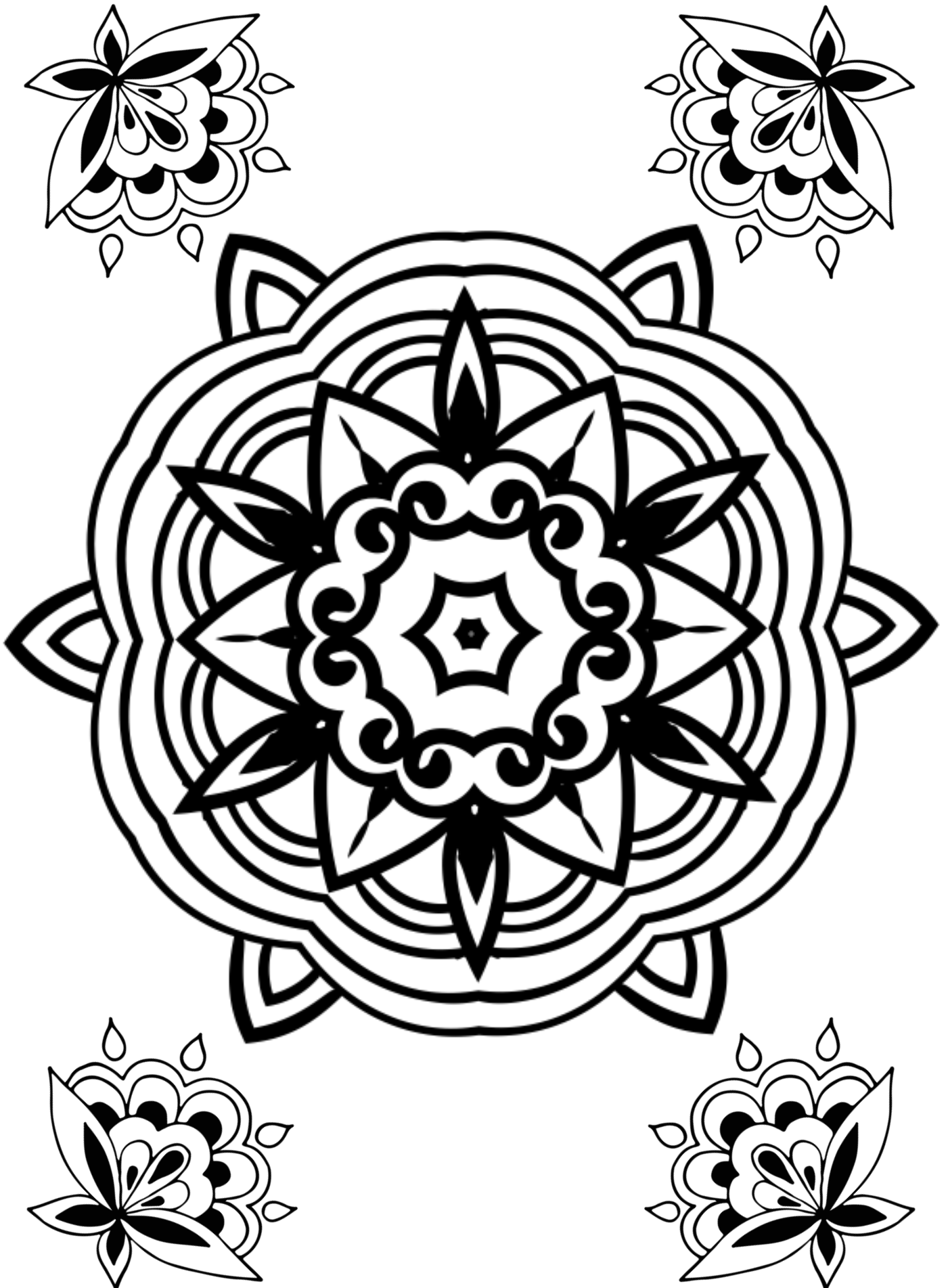

SOLUTIONS



Combine la bonne couleur avec le bon mot. /
Combine the right color with the right word.

ROUGE / RED

ROSE / PINK

JAUNE / YELLOW

MARRON / BROWN

VERT / GREEN

NOIR / BLACK

ORANGE / ORANGE

VERT CLAIR / LIGHT GREEN









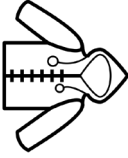
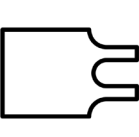
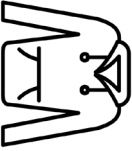
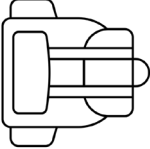

BLEU / BLUE

VIOLET / PURPLE

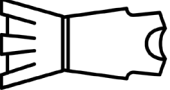
BLANC / WHITE

BLEU CLAIR / LIGHT BLUE

LES VÊTEMENTS / CLOTHES

	le t-shirt		la casquette		les lunettes
	la veste		le maillot de corps		le pull
	le sac à dos		le caleçon		le sac
	la robe		le pantalon		le short
	les tongs		les chaussettes		la chaussure

SOLUTIONS



LES VÊTEMENTS COLORÉS / COLOURED CLOTHES

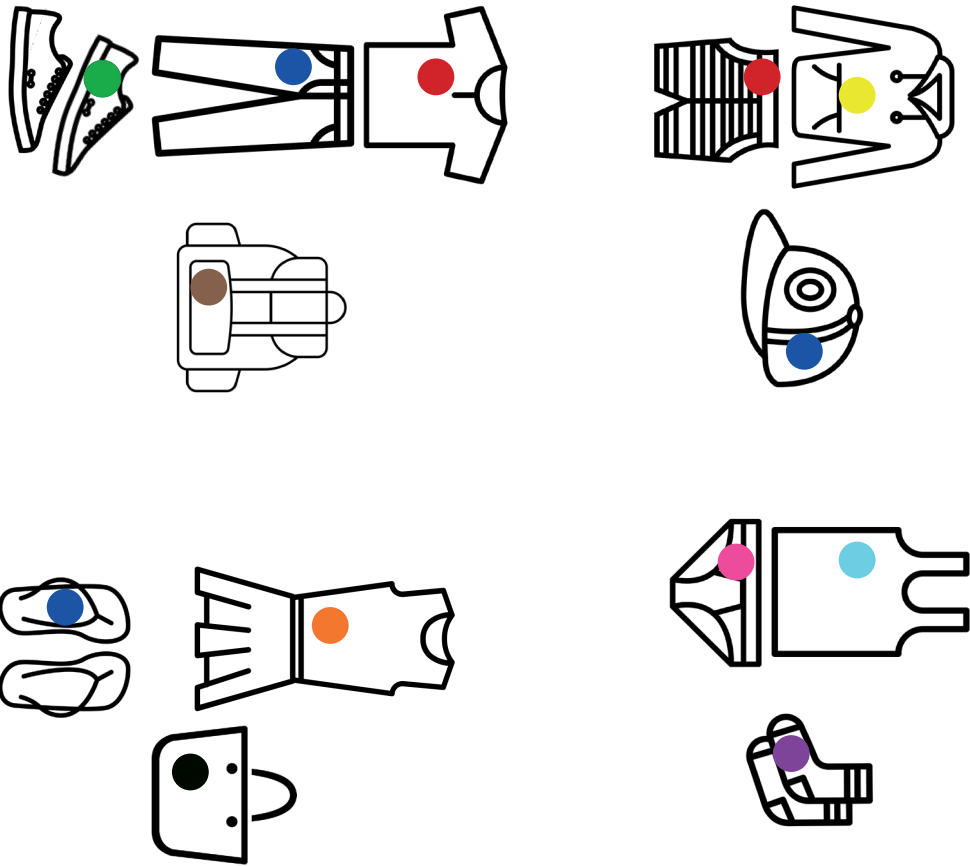

QUI HABITE OÙ ? / WHO LIVES WHERE?

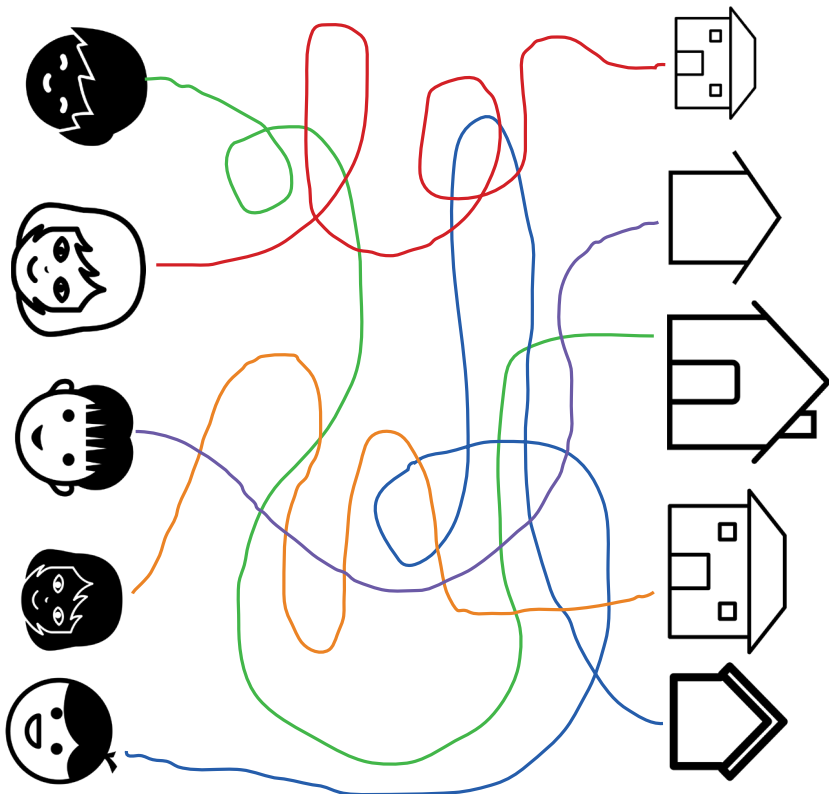



QUEL ANIMAL MANGE QUOI ? / WHICH ANIMAL EATS WHAT?

LES NUMÉROS DE 1 À 10 / NUMBERS FROM 1 TO 10

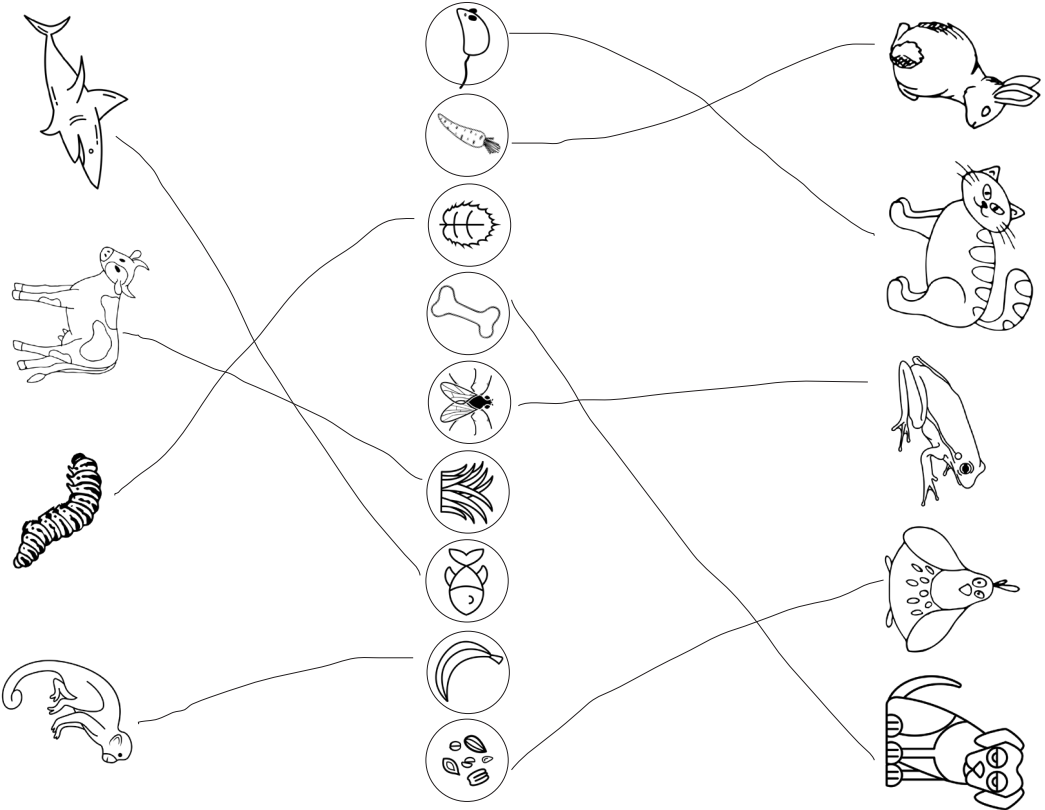

1 2 3 4 5 6 7 8 9 10

10 9 8 7 6 5 4 3 2 1

●● = 2

●●●● = 4

● = 1

●●● = 3

●●●●● = 5

●●●●●● = 7

●●●●●●● = 10

●●●●●●●● = 6

●●●●●●●●● = 9

●●●●●●●●●● = 8

SOLUTIONS



Save the Children

LES NUMÉROS DE 1 À 10 / NUMBERS FROM 1 TO 10

$7+1=8$	$1+1=2$	$2+2=4$
$1+4=5$	$1+3=4$	$5+5=10$
$2+5=7$	$5+1=6$	$1+3=4$
$2+3=5$	$3+3=6$	$4+4=8$
$4+4=8$	$4+3=7$	$7+2=9$
$1+1=2$	$7+1=8$	$8+1=9$
$9+1=10$	$8+1=9$	$9+1=10$
$2+8=10$	$2+8=10$	$2+8=10$
$1+3=4$	$2+3=5$	$4+3=7$
$7+1=8$	$1+7=8$	$9+1=10$
$3+3=6$	$4+3=7$	$6+3=9$
$2+3=5$	$2+3=5$	$2+7=9$
$1+4=5$	$1+4=5$	$7+1=8$
$5+1=6$	$5+3=8$	$5+4=9$
$3+7=10$	$2+7=9$	$3+1=4$

DE NOMBREUSES MAISONS COLORÉES / MANY COLOURFUL HOUSES

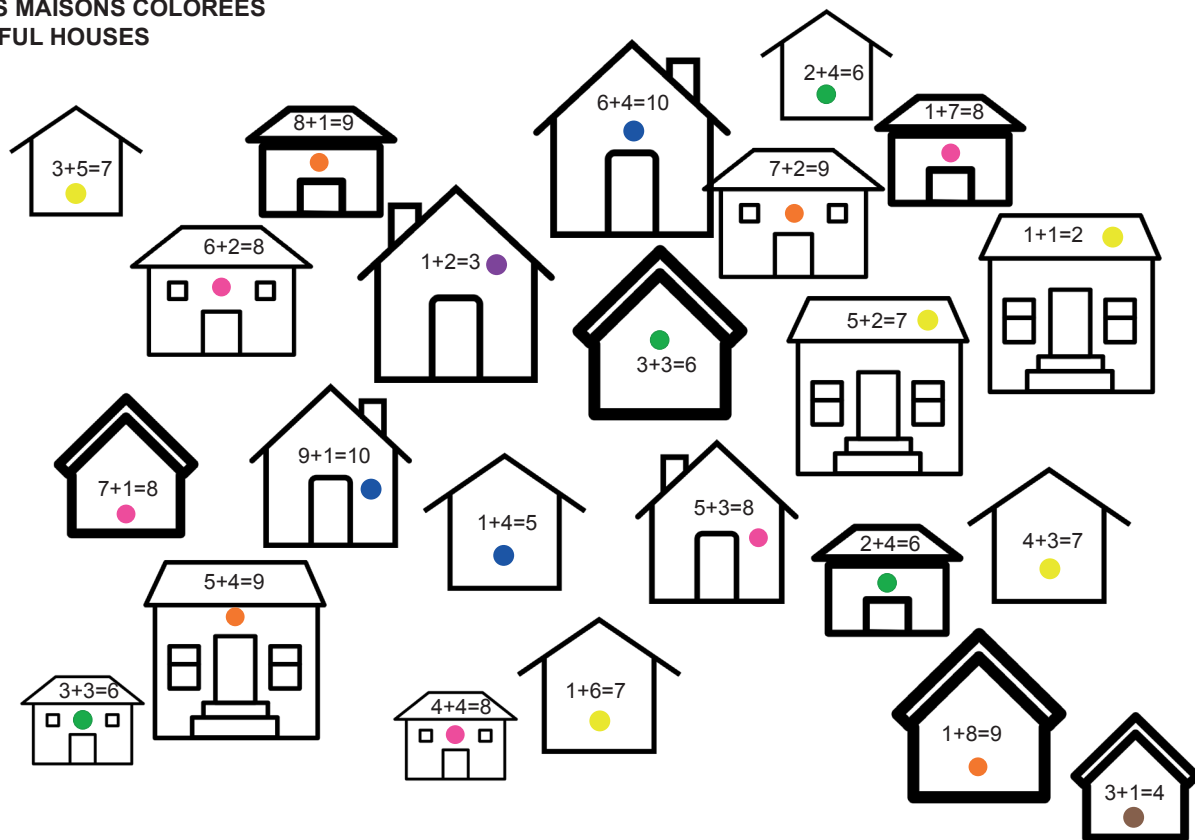



FRUIT OU LÉGUME ?
/ FRUIT OR VEGETABLE ?

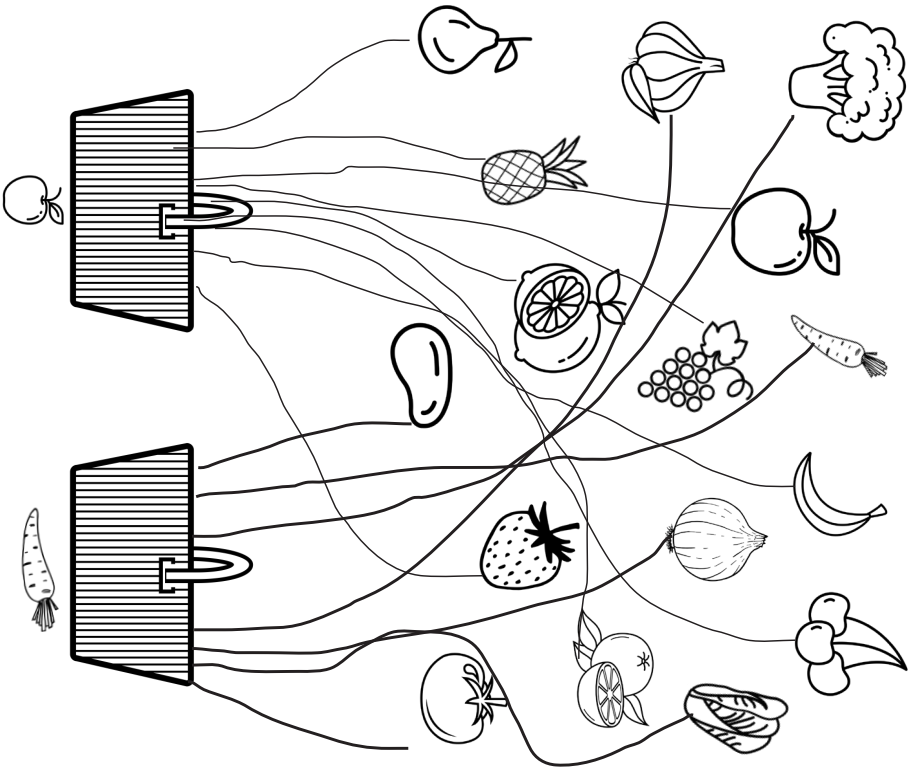

COMMENT S'APPELLENT CES FRUITS ET LÉGUMES ? /
WHAT ARE THESE VEGETABLES AND FRUITS CALLED?



Le brocoli



la pomme / the apple



la carotte / the carrot



la banane / the banana



le citron / the lemon



l'ail / the garlic



la poire / the pear



le raisin / the grape

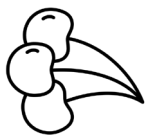

la cerise / the cherry

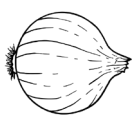

l'oignon / the onion



la pomme de terre / the potato

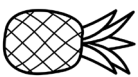

l'ananas / the pineapple



la tomate / the tomato



l'orange / the orange



la fraise / the strawberry



la salade / the salad

SOLUTIONS



Save the Children

LE CORPS / THE BODY



l'oreille



l'œil / the eye



le nez / the nose



la main / the hand



le doigt / the finger



la bouche / the mouth



le pied / the foot



les cheveux / the hair



la tête / the head

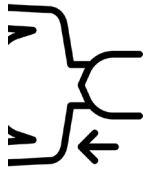

l'épaule / the shoulder



le genou / the knee



le bras / the arm



les dents / the teeth



la jambe / the leg

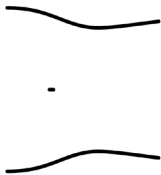

le ventre / the belly